

# Light-O-Rama



## *CTB-16D*

### Computerized Light Controller

User Manual  
October 24, 2007  
V1.01

Copyright © Light O Rama, Inc. 2007

# Table of Contents

Introduction .....	5	Installing LOR Software.....	25
What's in the Box.....	6	Connecting Controller-to-PC Data Cable .....	26
Safety Considerations.....	6	Configuring the Communications Port.....	27
CTB-16D Component Locations .....	7	Creating A Sequence.....	29
Getting Started.....	7	Triggering (Starting) a Sequence.....	34
Wiring the CTB-16D.....	8	Power On Mode .....	34
General Information:.....	8	Input Control Mode.....	34
Power Input to the CTB-16D .....	9	Stand Alone Operation.....	35
Single Feed Configuration (20 amps max) .....	9	Troubleshooting .....	36
Dual Feed Configuration (40 amps max) .....	10	Autoconfigure does not find COM Port.....	36
Power Output – Wiring Output Circuits.....	10	Refresh does not find the controller.....	37
Connecting Channels 1-8 to the Board.....	11	CTB-16D Status LED not Blinking.....	38
Connecting Channels 9-16 to the Board.....	11	Channel 9-16 OK, Channels 1-8 No Good .....	39
Identifying the Unit .....	12	Specifications and Features.....	40
Quick Start Guide .....	13	Warnings and Liability.....	41
Connecting Up the CTB-16D .....	15	Appendix A Hexadecimal to Decimal.....	42
Connecting to a PC .....	15		
Connecting to a LOR1602MP3 .....	16		
Connecting to a Show Director.....	17		
Connecting to another Controller .....	17		
Creating a Show .....	18		
Creating a Show (Full Capabilities).....	18		
Power Considerations.....	19		
Single Power Feed.....	19		
Dual Power Feed .....	19		
3-Phase Power .....	20		
Christmas Light Power Consumptions .....	21		
Hardware Description .....	22		
Status LED .....	22		
Assigning a Unit ID.....	22		
Stand Alone Speed Control.....	23		
J0 Header.....	24		
Testing with the Hardware Utility .....	25		

## Introduction

The CTB-16D is a 16 channel computerized lighting controller board from the Components Line of Light O Rama (LOR) products. It is available with and without heat sinks. This controller can generate a number of lighting effects including dimming, ramping, twinkling and shimmering.

A CTB-16D can be used in many ways:

- By daisy chaining it off of an LOR1602MP3 Show-in-a-Box lighting controller with Show Director
- By connecting it to your PC running the LOR Showtime Windows software
- By connecting it to one of LOR's Show Directors (DC-MP3 or mDM-MP3)
- By running a stand alone set of commands loaded into the controller's flash memory
- By daisy chaining it off of another controller that is either running stand alone or getting its commands from one of the other sources listed above

To operate this controller you will also need the LOR software package and a LOR RS485 adapter to communicate with a PC.

## For use with incandescent lamps and line voltage LED strings

## What's in the Box

In addition to your CTB-16D lighting controller you will also receive this user manual.

The latest copy of this manual is available at [www.lightorama.com](http://www.lightorama.com) ► *Support* ► *Using the Hardware – Documentation and Firmware* section.

## Safety Considerations

**CAUTION:** This product requires that the you have an understanding of electrical wiring. It requires connections to 120/240 VAC. The board has many exposed high voltage connections which are potentially dangerous. The CTB-16D should be placed in a safe enclosure ensuring the safety of children and pets.

When connecting the communications link or setting the Unit Id, make sure that the unit is not plugged in or be very careful.

## CTB-16D Component Locations

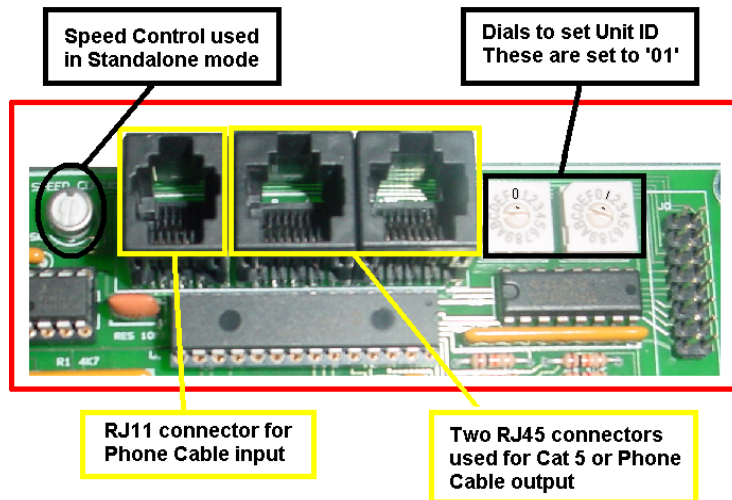

Figure 1

## Getting Started

There are three steps to making the CTB-16D useful.

1. It must be wired to accept one or two AC power sources and wired to distribute AC power from its 16 output circuits.
2. It must be connected to a Windows PC to receive commands.
3. The LOR Hardware Utility can be used to test the controller and the LOR Sequence Editor can be used to create a “sequence” to direct the controller.

## Wiring the CTB-16D

### General Information:

Generally HOT wires are BLACK or BROWN and Neutral wires are WHITE or BLUE. If you use lamp cord type wire, usually one of the wires has smooth insulation and the other wire has ribbed insulation. The wire with smooth insulation is HOT.

On a standard grounded outlet, the round hole is ground the short slot is HOT and the longer slot is NEUTRAL.

Wires should be carefully stripped to a length (about 1/3 inch) where the bare conductor can be inserted fully into the connector and no bare conductor is exposed.

Frayed wires can cause short circuits that will damage the unit and pose a fire hazard. Carefully inspect all connections before applying power to insure that there are no short circuits.

The screw holding the wire in place must be tightened firmly. Pull on connected wires to ensure good mechanical connection. A loose wire can cause overheating and pose a fire hazard.

**CAUTION: SHOCK HAZARD THIS BOARD HAS MANY EXPOSED HIGH VOLTAGE CONTACTS. DISCONNECT POWER WHEN THE BOARD IS BEING WORKED ON. PLACE THE BOARD IN A SAFE OPERATING ENVIRONMENT.**

### Power Input to the CTB-16D

The CTB-16D can be wired with 1 or 2 power feeds. Each power feed can supply up to 20 amps, so a total power capacity of 40 amps is possible.

The CTB-16D is delivered with 15 amp fast acting fuses. You should replace them with 20 amp fast acting fuses if you intend on delivering over 15 amps per side.

### Single Feed Configuration (20 amps max)

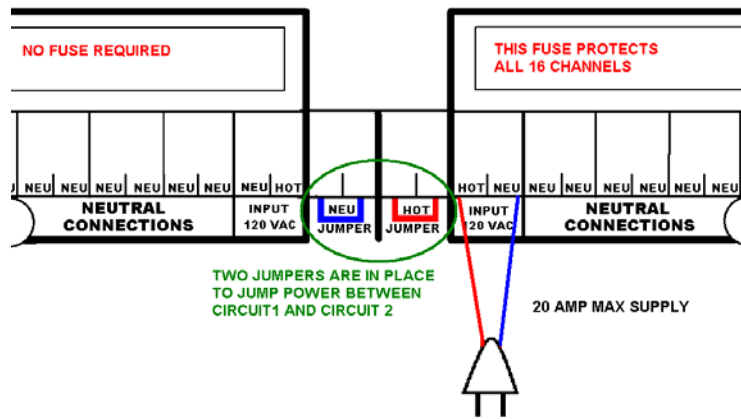

In this configuration a single power line is connected to the board. This power cable used should be 14 awg for 15 amps and 12 awg for 20 amps.

Jumpers (small wires the same gauge as the power feed cable) are used to bridge power from one side of the card to the other side. Without the jumpers in place the circuits on the left side of the card will not have power. The fuse on the right side of the card protects all 16 channels. A fuse is not required on the left side of the card.

### Dual Feed Configuration (40 amps max)

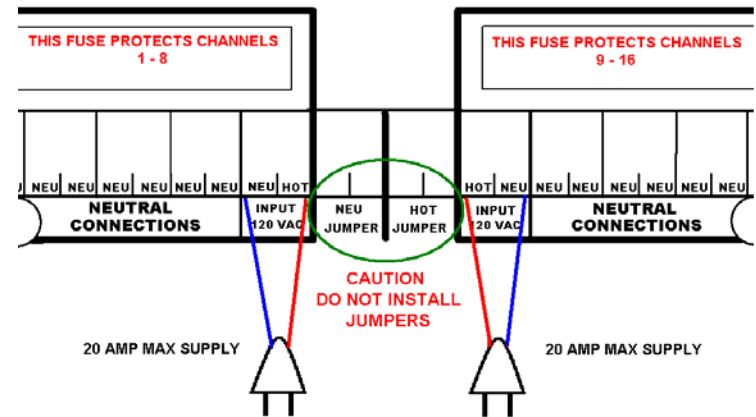

In this configuration two power feeds are connected to the board. The power cable used should be 14 awg for 15 amps and 12 awg for 20 amps.

**WARNING: NO JUMPERS ARE INSTALLED IN THIS CONFIGURATION**

### Power Output – Wiring Output Circuits

Each output channel of the CTB-16D can handle 2 amps without a heat sink. 8 amps with proper heat sinking. There are 16 numbered output channels which are marked HOT and connected to the HOT side of the output connector. There are 16 Neutral terminals where you can conveniently terminate your neutral wires. Neutrals can be connected off the card if that is more convenient.

**WARNING: Connect the neutral wires for channels 1-8 on the left hand side of the card and the neutral wires for channels 9-16 on the right hand side of the card.**

Note: Neutral wires can be placed in any of the 8 neutral connections on one side of the card. Order of placement is not important.

### Connecting Channels 1-8 to the Board

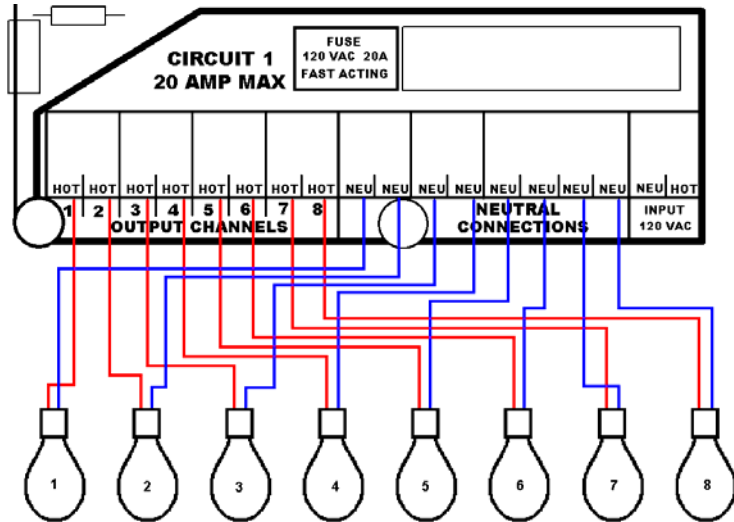

### Connecting Channels 9-16 to the Board

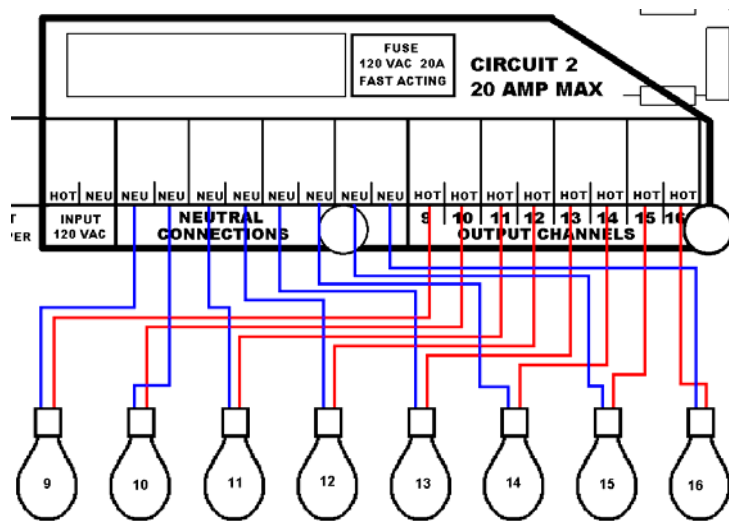

## Identifying the Unit

Each LOR lighting controller used in a network must have a unique ID assigned. Every channel that you control in a sequence has to identify a particular channel on a particular Unit.

For example, in a sequence that you construct, channel 32 may be assigned to Unit 3 circuit 10. Because the controllers are daisy chained together, every controller sees every command sent but Unit 3 will only react to commands that are marked "for Unit 3."

The two hex, rotary dip switches (circled in red) are used to set a controller's Unit Id. Valid Unit Id values are 01 to F0. 00 is not a valid Unit Id.

To set the unit Id to "01," set **S1**=0 and **S2**=1

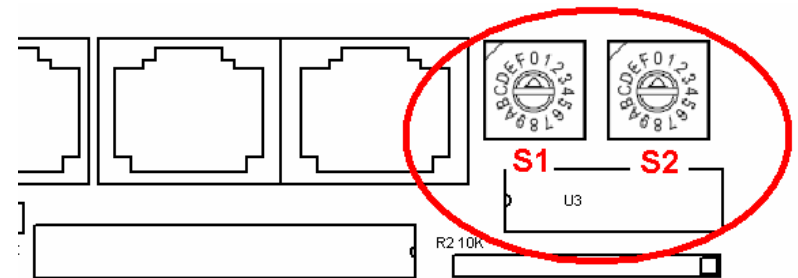

## Quick Start Guide

This section gets you going in the common case where you bought the SPK-ST Generic Start Kit (Showtime Windows software, RS485 adapter and LAN connecting cable.) The Showtime software on your PC will be used to direct your CTB-16D.

If you have problems, see the detailed sections: *Connecting up the CTB-16D* and *Testing with the Hardware Utility*.

- (1) Install the Showtime PC software.
- (2) Install the RS485 adapter. If you have the SC485 serial port adapter, just plug it into a serial port on the back of your PC. If you have one of the USB adapters (USB485 or USB485B) follow the directions that came with the adapter.
- (3) Wire up the CTB-16D as explained in “Wiring the CTB-16D” section.
- (4) Set the Unit Id as explained in the “Identifying the Unit” section.
- (5) Plug the LAN cable into the RS485 adapter connected to your PC and into either of the large jacks at the top of the controller.
- (6) Plug in the CTB-16D power cord(s), the Status LED should be blinking.
- (7) Start the Light O Rama Control Panel: click **start ► All Programs ► LightORama ► Light-O-Rama Control Panel**. Answer OK to any initialization boxes. There will be a light bulb with a blue halo on the right side of the task bar at the bottom of the screen. Right-click the light bulb and

select *Hardware Utility* (HWU) from the menu. You will see this window:

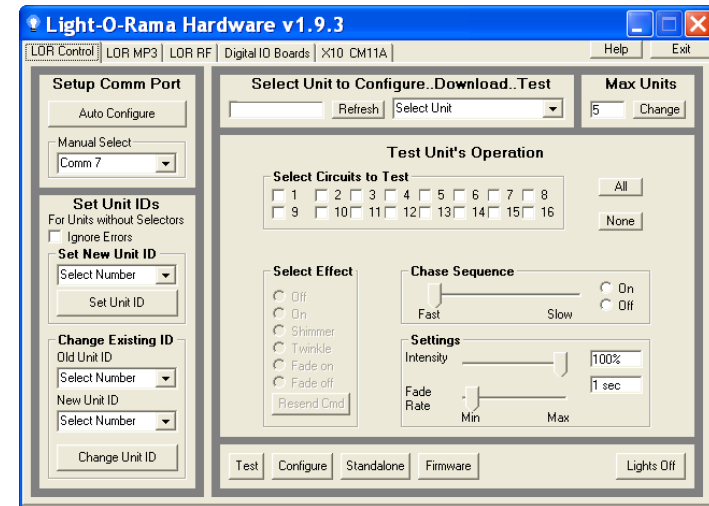

- (8) Click the *Autoconfigure* button on the upper left. The HWU will search for the Light O Rama port.

Tip: Under “Max Units” on the upper right, click the *Change* button and move the slider to select 10 units. This will cut down the scan time because the HWU will not have to scan for 240 controllers. Click OK.

- (9) Click the *Refresh* button at the center top. The HWU will scan for all connected controllers. Your controller will appear in the drop down menu to the right of the *Refresh* button.
  - (10) Plug some lights into the CTB-16D and use the “Test Unit’s Operation” section to turn on lights, etc.
- If you would like to create a simple sequence, see the *Creating a Sequence* section.

## Connecting Up the CTB-16D

In order to use your CTB-16D, you must connect it to a show director, Windows PC or run it in stand alone mode (see the *Stand Alone Operation* section.)

### Connecting to a PC

You will need the following to connect your CTB-16D lighting controller to a PC:

- Showtime Windows Software
- RS485 Adapter
- CAT5e LAN cable or phone cable
- Your CTB-16D
- Windows PC running 98 SE, 2000, ME, XP or Vista

The first three items are available in the LOR SPK-ST Generic Starter Package. [www.lightorama.com](http://www.lightorama.com) ► *Web Store* ► *Showtime Products*. You will have to choose an RS485 adapter type. It's best to go with the USB485 if you have no intention of going wireless from your PC to the controller. If wireless is desired, get the USB485B.

The following diagram shows how the pieces fit together:

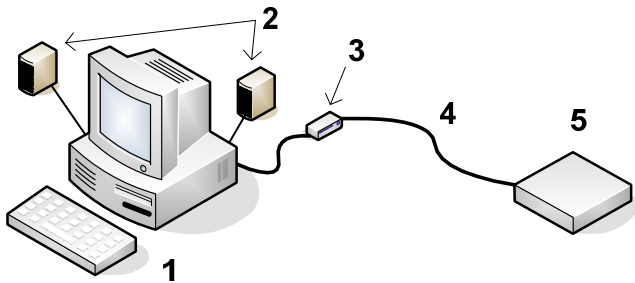

1. Your PC running the Showtime Windows Software
2. Your PC speakers to play the music
3. RS485 Adapter to convert short distance USB to long distance RS485
4. Phone or CAT5e LAN cable
5. CTB-16D lighting controller in your enclosure

If your USB adapter has more than one jack, you can use either.

If you are using phone cable to connect the RS485 adapter to your controller, make sure you use the "Phone Cable In" jack on the CTB-16D. (See the "CTB-16D Component Locations" section.) If you are using CAT5e LAN cable, you can use either of the larger jacks on the controller.

### Connecting to a LOR1602MP3

You will need the following to connect your CTB-16D lighting controller to an LOR1602MP3 "Show in a Box Controller":

- LOR1602MP3
- Phone or CAT5e LAN cable
- Your CTB-16D

If you are using phone cable to connect the LOR1602MP3 to the CTB-16D, make sure you use either one of the large jacks on the LOR1602MP3 and the "Phone Cable In" jack on the CTB-16D. See the "CTB-16D Component Locations" section.

If you are using CAT5e LAN cable, you can use either of the large jacks on either controller.



## Connecting to a Show Director

You will need the following to connect your CTB-16D lighting controller to a Show Director:

- mDM-MP3 or DC-MP3 Show Director
- Phone or CAT5e LAN cable
- Your CTB-16D

If you are using phone cable to connect a show director to the CTB-16D, you can use either jack on the show director. Make sure you use the “Phone Cable In” jack on the CTB-16D. See the “CTB-16D Component Locations” section.

If you are using CAT5e LAN cable, you can use either jack on the show director and either of the large jacks on the CTB-16D.

The cable connecting a show director to the controller should be 50’ or less in length. Longer cables may result in a voltage drop causing erratic operation of the show director.

## Connecting to another Controller

If you are using phone cable to connect two controllers together, always go from either of the large jacks on one controller to the “Phone Cable In” jack on other controller. See the “CTB-16D Component Locations” section.

If you are using CAT5e LAN cable, you can go from either large jack on one controller to either large jack on the other controller.

## Creating a Show

The simplest way to create a show is to purchase pre-made musical sequences from LOR. These can be purchased in sets on a CD, or individually via download from the LOR website. To see the currently available musical sequences, go to [www.lightorama.com](http://www.lightorama.com) ► *Web Store* button (upper right) ► *Musical Sequences* button (left.)

You can also create the sequences yourself using the Showtime Windows software. See the *Creating a Sequence* section.

Once you have the sequences on your PC, the *Simple Show Builder* is the easiest way to arrange these sequences into a show and schedule the show.

The *Simple Show Builder* installer can be downloaded from [www.lightorama.com](http://www.lightorama.com) ► *Support* ► (bottom of the page) *download* button for *Simple Show Builder*. Run this installer to install the SSB on you PC. Use Windows Explorer to browse to C:\Program Files\Light-O-Rama\LORSimpleShowBuilder.exe and double click it. Follow the instructions on the screen to create your show. In a few simple screens, you will have arranged your musical sequences into a show and scheduled this show.

## Creating a Show (Full Capabilities)

If you are looking for more flexibility in your show, the following features not available with *Simple Show Builder*:

- More than one show

- More flexible scheduling
- Interactive shows

See the Showtime Windows software guide for more information on running shows from your PC using the Showtime Windows software.

See the DC-MP3 User Manual for more information on running shows with a DC-MP3 Show Director.

See the mDM-MP3 User Guide for more information on running shows with an mDM-MP3 miniDirector.

## Power Considerations

This section attempts a relatively simple answer to the question “How many lights can I use?”

### *Single Power Feed*

The maximum current on a single channel is 8 amps. The maximum current for all channels is 15 or 20 amps, depending upon how you wired the controller. So you have to divide up your lights on the 16 channels so you don't exceed these two limits.

Assuming a 15 amp power feed, you could put 1 amp on 14 channels and 0.5 amps on 2 channels and that would be 15 amps. Or, you could put 0.5 amps on 14 channels, 8 amps on another channel and 0 amps on the last channel and that would be 15 amps.

### *Dual Power Feed*

The left input cord powers channels 1-8. The right power input cord powers channels 9-16 and the

controller's microcomputer. The maximum on each power cord is either 15 or 20 amps, depending upon how you wired the controller.

If you plug both power cords into one circuit, then the controller would have at most 20 amps available, but more likely, the circuit is a 15 amp circuit, so that's all you'll have available. If you can plug the two power cords into separate circuits, then the full 30 or 40 amp capacity of the controller will be available.

We will talk about only the right channels for now. The same discussion applies to the left channels.

The maximum current on a single channel is 8 amps. Assuming a 15 amp power feed, the maximum current for all right channels is 15 amps. So you have to divide up your lights on the 8 channels so you don't exceed these two limits.

You could put 1 amp on 7 channels and 8 amps on the last one and that would be 15 amps. Or, you could put 2 amps on 6 channels, 1 amp on another channel and 2 amps on the last channel and that would be 15 amps.

The same computation applies to the left bank of channels. Remember, if the controller is plugged into only one circuit in your house, then both the left and right banks' total current must not exceed what that circuit can supply.

### **3-Phase Power**

Both power cords of a CTB-16D must be plugged into the same phase in commercial 3-phase environments. If they are not, channels 1-8 will not be flashing in sync with the Show Director or PC.

### Christmas Light Power Consumptions

The following table gives the approximate current consumption for various types of Christmas lights.

Description	Lights/string	Amps/string
Mini-lights	50	0.17
Mini-lights	100	0.33
C7 bulbs	25	1.04
C9 bulbs	25	1.5
100 watt bulb	1	0.75
150 floodlight	1	1.25
LED mini-lights	70	0.03
LED C6 or C7	25	0.02

If you put six sets of 100 mini-lights on one channel, that would be  $6 * 0.33 =$  about 2 amps. If you put six sets of 70 LED mini-lights on one channel, that would be  $6 * 0.03 =$  about 0.18 amps. You can see that you can get a lot of LEDs with very little power.

Make a chart of all the lights you want to connect to the controller's channels and then work out the numbers to see if you hit any limits.

### Hardware Description

#### Status LED

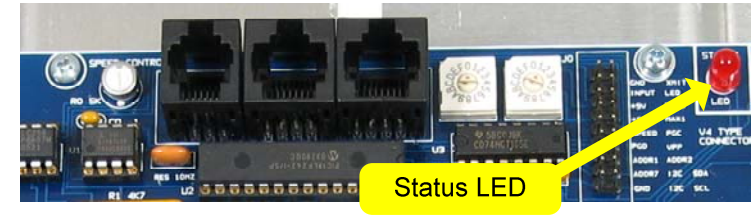

- LED blinking approximately twice/second:* Controller has booted correctly and is waiting for commands. The controller is not connected to a Light O Rama network or the network is not active.
- LED is on solid:* Controller is connected to an active network (is receiving the heartbeat and commands from a PC, a show director or another controller)
- LED blinks on for a long pulse and off for a short pulse:* Controller firmware needs to be downloaded. See the *Updating Controller Firmware* section.
- LED flutters:* Controller is running a standalone sequence or downloading firmware.

#### Assigning a Unit ID

Each LOR light controller used in a network must have a unique ID assigned. [If two controllers are given the same unit ID, then they will both perform the same effects.] Every channel that you control in a sequence (a *sequence* is a set of lighting controller commands constructed using the Showtime Windows software) has to identify a particular output circuit on a particular lighting controller (Unit.)

For example, in a sequence that you construct, a channel you call “Front door” may be assigned to Unit ID 03 circuit 10. Because the controllers are daisy chained together, every controller sees every command sent but Unit 03 will only react to commands that are marked “for Unit 03.”

The two hexadecimal rotary dip switches (shown in the next picture) are used to set a controller’s Unit ID. Valid Unit ID values are 01 to F0 (1 to 240 decimal.) 00 is not a valid Unit ID.

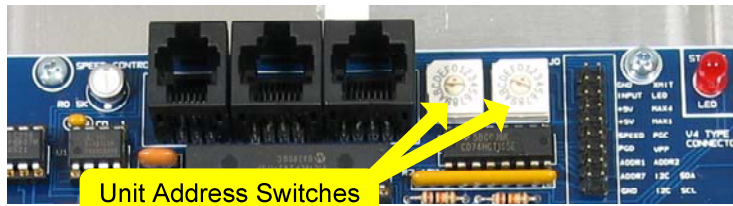

To set the Unit ID to '01,' the left rotary switch would be set to '0' and the right rotary switch would be set to '1.'

See Appendix A for a conversion of Hexadecimal controller unit IDs set with the switches and their decimal equivalents.

**Stand Alone Speed Control**

A standalone sequence is a sequence that has been downloaded into the flash memory of the lighting controller. See the *Stand Alone Operation* section for more information.



This little potentiometer allows you to adjust the speed at which a standalone sequence is executed. In the center position the sequence will execute at the rate specified in the sequence. That is 1 second in the sequence will take 1 second to execute. The sequence may pause slightly when adjusting the speed. This is normal.

**J0 Header**

The following two figures show the J0 header that is to the right of the Unit ID Switches. Normally, you would not connect anything to this header, however, for standalone operation the figures show how to connect a switch to the controller. This switch can be used to start a stand alone sequence. See the *Stand Alone Operation* section for more information.

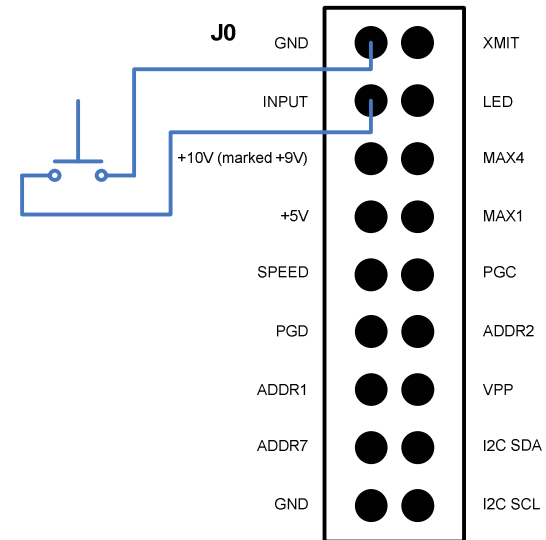

18 Pin Header on Newer Boards

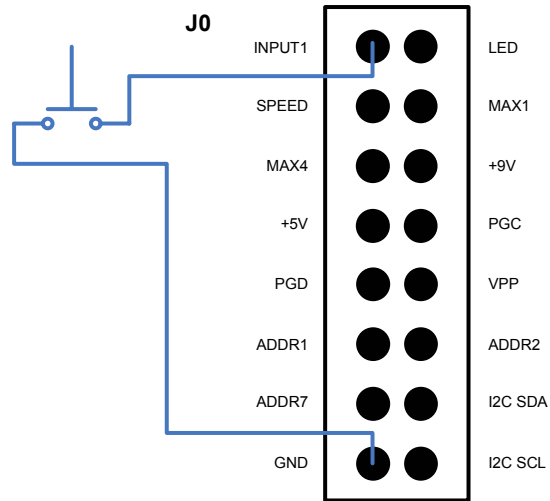

16 Pin Header on Older Boards

## Testing with the Hardware Utility

Use this section to learn how to connect your controller to your PC. If you have already installed the RS485 adapter and verified its operation with another controller, you can skip to the *Creating A Sequence* section.

Once power has been supplied to the CTB-16D the Status LED will begin to blink. This indicates that the Unit is functioning and that there is no communication. Once communication with a PC, show director or another controller is established, the LED will light steadily.

## Installing LOR Software

You must have the LOR ShowTime software installed on your PC to proceed. Follow the instructions that came with the software to install it.

## Connecting Controller-to-PC Data Cable

If you want to experiment with the lighting controller using the LOR Windows Software, you will have to install an RS485 adapter so you can talk to it from your PC.

If you have an SC485 (PC serial port adapter, shown on the left in the following picture), you need only plug it into an available PC 9-pin serial port. The cable from this serial adapter to the controller is limited to 100' or less.



If you have one of the USB adapters (shown in the previous picture on the center and right), follow the installation instructions that came with the adapter to install it. If your adapter has two jacks, you can use either.

If you are using telephone cable to connect your controller to the RS485 adapter, plug one end of the phone cable into the adapter and the other end of the cable into the Phone Cable In jack as indicated in the next picture.

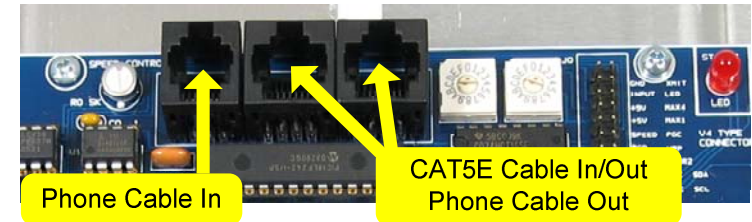

If you are using CAT5E LAN cable to connect your controller to the RS485 adapter, plug one end of the data cable into the adapter and the other end into either of the *CAT5E Cable In/Out* jacks shown in the previous picture.

### Configuring the Communications Port

First start the Showtime software control panel by clicking **start ► All Programs ► LightORama ► Light-O-Rama Control Panel**. There will be a light bulb with a blue halo on the right side of the task bar at the bottom of the screen. Right-click the light bulb and select *Hardware Utility* (HWU) from the menu. You will see this window:

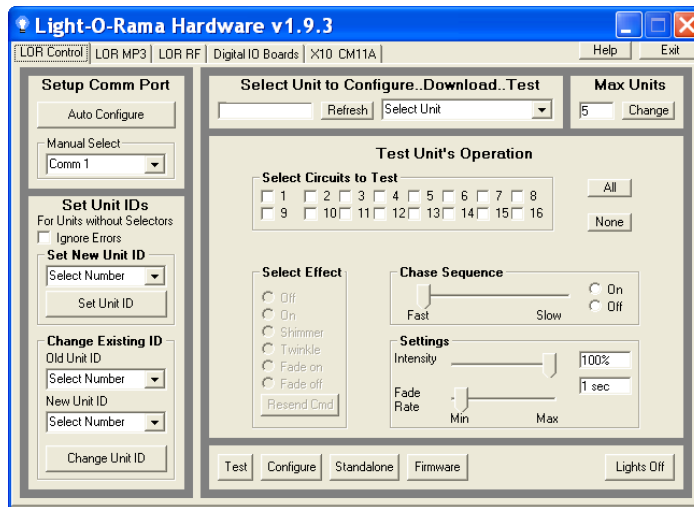

With your controller powered up and cabled to your PC, click the *Auto Configure* button on the top left. The HWU will pop up a window asking you to make sure everything is connected, click OK. It will then search through all ports on your PC looking for the

port being used by Light O Rama and you will see this window:

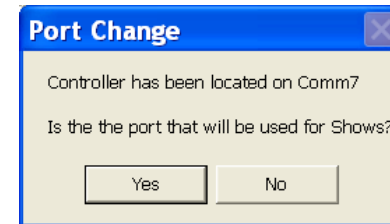

Click *Yes*, your RS485 adapter has been located and is functioning properly. This will also make this port available to other LOR software, like the Sequence Editor which is used to create your light shows. See the *Troubleshooting* section if you have problems.

**TIP:** The **REFRESH** command can take a long time scanning for all possibly Unit IDs. To speed things up, set the *Max Units* (upper right of window) to a number slightly larger than the maximum Unit ID you plan on using. See Appendix A if you have Unit IDs above 09 to convert hexadecimal to decimal.

Click the *Refresh* button (center top of window) to have the Hardware Utility scan for all controllers attached to the PC. When it finishes, the drop down menu to the right of the *Refresh* button will list all controllers found. Use this menu to select your controller. See the *Troubleshooting* section if you have problems.

You can use the “Test Unit’s Operation” portion of the window to test the controller. Make sure you have some lights plugged into the controller and then click the radio buttons under “Select Effect.”

This is a good time to experiment with different intensities, fade rates and chase speeds. This information will be useful if you want to create your own light shows.

## Creating A Sequence

This section assumes that you have used previous sections to configure your controller and attach it to your PC. If you haven't done this, see the *Assigning a Unit ID* and *Testing with the Hardware Utility* sections.

The following screen shot is for later reference, it shows the Sequence Editor with the completed test sequence and labels for the functions used.

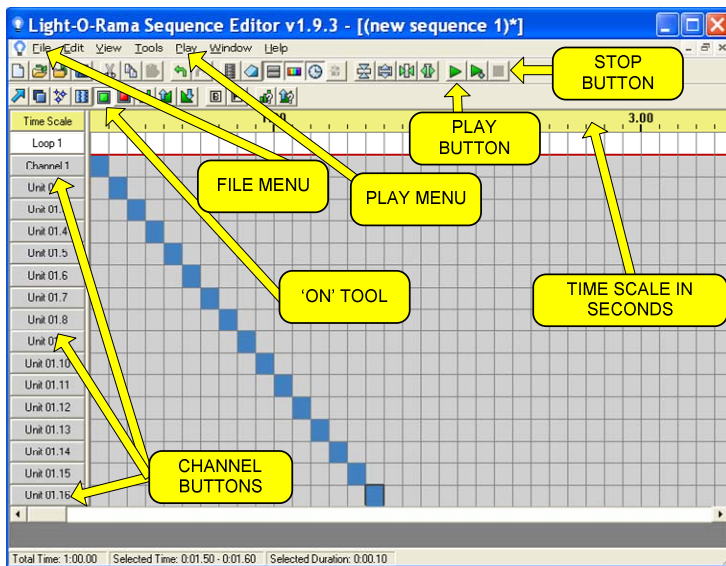
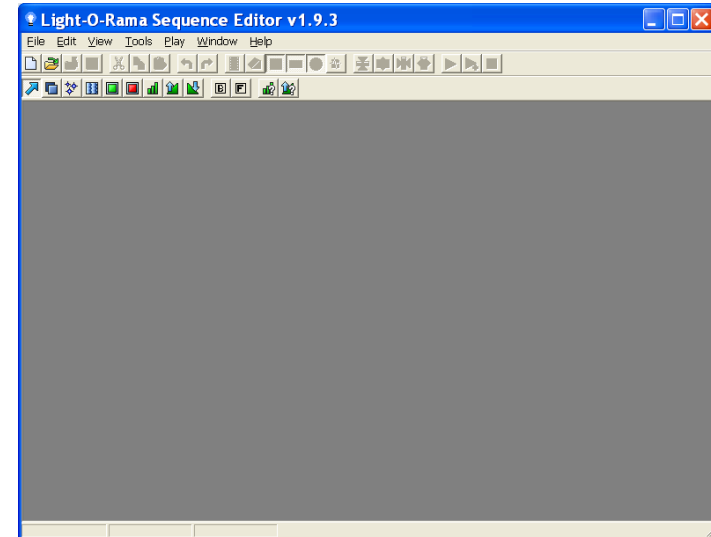

Figure 2

First start the Showtime software control panel if it is not already running by clicking **start ▶ All Programs ▶ LightORama ▶ Light-O-Rama**

**Control Panel.** There will be a light bulb with a blue halo on the right side of the task bar at the bottom of the screen. Stop the Hardware Utility if it is running because only one LOR program may use the communications port at a time. Right-click the light bulb and select *Sequence Editor* from the menu and you will see this window:



Click **File ▶ New ▶ Animation Sequence** and you will see this window:

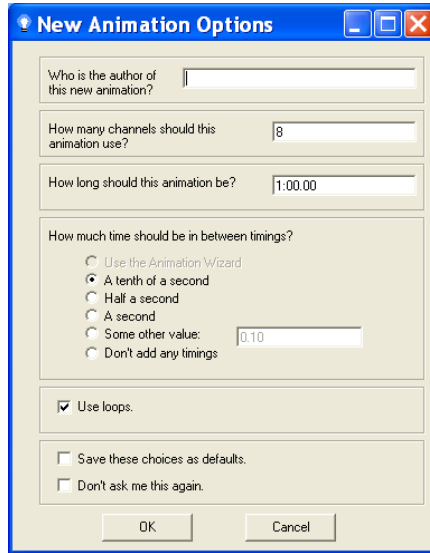

Set the number of channels to 16, the rest of the options can be left as is and click OK. You will see this window:

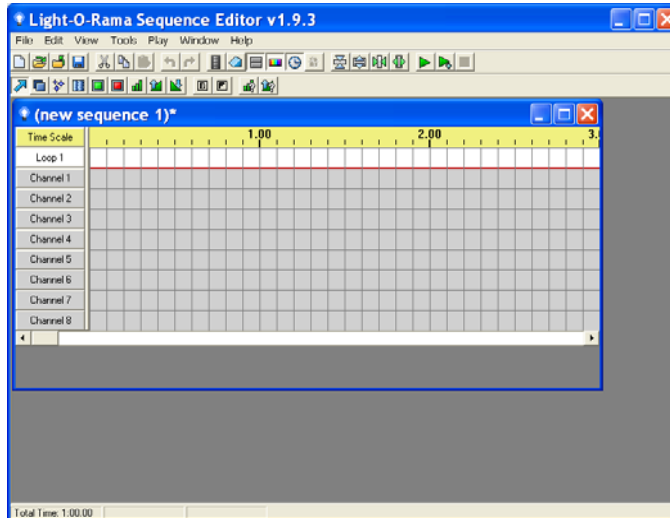

Click the *Channel 1* button ( on the left of the window.) In the *Channel Settings* window that pops

up use the “Device Type” drop down menu to select “Light-O-Rama” controller. Set the Unit to ‘01’ (or the Unit ID of your controller if different) and set the Circuit to 1. Circuit number 1 corresponds to Output Circuit 1 on the controller. When you click OK, the *Autopopulate* box will appear, use the drop down menu in the box to select “Sixteen Channels” and click OK.

You can also configure each channel individually by clicking its channel button and setting its device type, unit ID and circuit number.

You now have a blank sequence grid with the channels configured. Click the sequence grid maximize button to expand the grid and it will look like this:

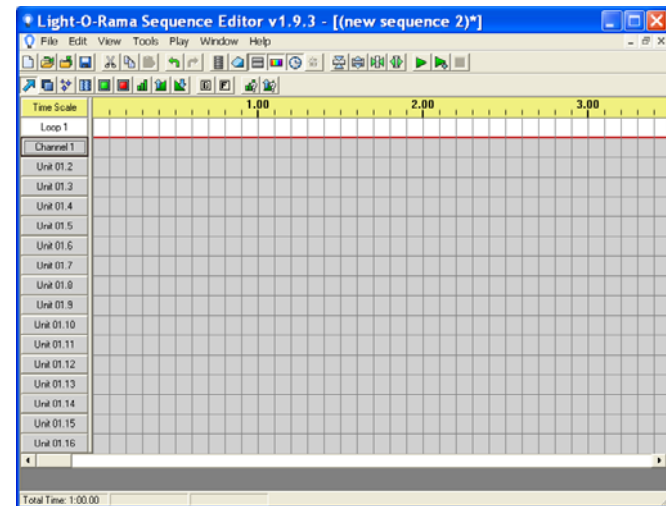

The rows in this grid represent the circuits on the lighting controller. The “Channel 1” row is circuit 1, “Unit 01.2” is circuit 2, ... If you look at the output pigtails on the controller, you will see small number



bands on each socket – these correspond to the grid rows now.

The columns in the grid represent time increasing to the right.

Click the 'on' tool. It is in the effects tool bar which is just above the row labeled "Time Scale." (Refer back to Figure 2) The 'on' tool is the square green button. If you click it and then click in the grid, it will turn 'on' the lights for those circuits at the times you click. In the following example, I have clicked to turn each light on in sequence for a 10<sup>th</sup> of a second during the first 1.6 seconds of the sequence.

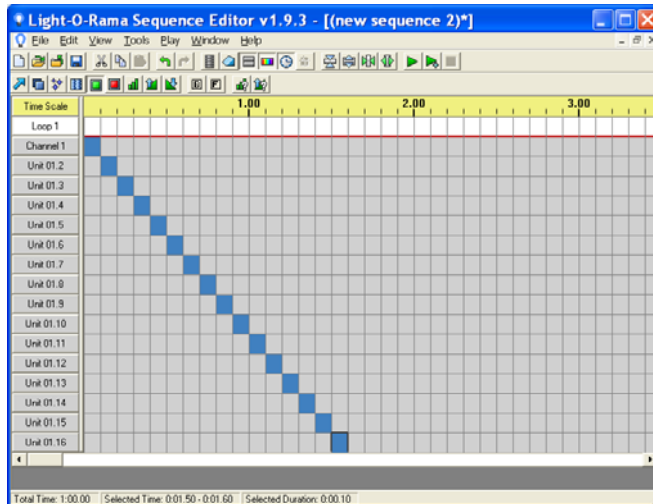

In the top tool bar, make sure *Control Lights* in the *Play* menu is checked. (Refer back to Figure 2)

Clicking the green play arrow (button) in the second tool bar will run your sequence. The red box to the right of the arrow is the stop button. If you have lights plugged into the controller, this simple sequence will light them in circuit order. You have created your first sequence.

There are Quick Start Guides for creating animation (non-musical) and musical sequences, Flash Tutorials on this subject and much more at:

[www.lightorama.com](http://www.lightorama.com) ► **Support**

The following Wiki is also an excellent source of information on all things Light-O-Rama:

[www.lorwiki.com](http://www.lorwiki.com)

There is a very active and helpful group of people on the Light O Rama bulletin board:

<http://lightorama.mywowbb.com>

There is also a very active and helpful user community on the Planet Christmas bulletin board::

[www.planetchristmas.com](http://www.planetchristmas.com)

## Triggering (Starting) a Sequence

In the *Hardware Utility*, when you download a stand alone sequence, you can specify what trigger condition will be used to start that sequence. A stand alone sequence can be triggered one of two ways: *Power on* and *Input Control*.

### **Power On Mode**

This means that the sequence will run anytime that power is supplied to the controller. You plug it in and it plays until you unplug it.

### **Input Control Mode**

This uses the input pin on the controller to determine when the sequence will run. When the input pin is connected to the ground pin the sequence will run one time and then check to see if

the pin is connected to ground. For more information on trigger conditions see the help for the *Hardware Utility*.

For information on how to connect the switch to the controller, see the *JO Header* section.

## Stand Alone Operation

A stand alone animation sequence (sequence with no accompanying audio) can be downloaded into the flash memory of the lighting controller's microprocessor.

This sequence can contain approximately 5,000 commands. These commands can also be for controllers other than this controller, so this controller can direct a network of controllers. There are no restrictions on the types of LOR controllers in this network.

The sequence is designed and tested using the Showtime Software Sequence Editor. When you are happy with the sequence, save it and stop the Sequence Editor.

Start the Hardware Utility and click the *Refresh* button to find the CTB-16D. Use the drop down menu next to the *Refresh* button to select the controller.

Click the *Standalone* button at the bottom of the window. Select one of "Run when power is on," "Input (norm open switch)" or "Input (norm closed switch.)" Click the *Send Trigger info to Unit* button.

Finally, Use the *Open* button to browse to your sequence and click the *Download* button.

You also use this screen to remove downloaded standalone sequences. You can also remove a standalone sequence by turning the controller off, setting the Unit ID switches to '00' and turning it on for 10 seconds. Then turn it off and reset the Unit ID switches to the original value.

## Troubleshooting

### ***Autoconfigure does not find COM Port***

If the automatic method of determining the communication port used by LOR does not work, you may be able to locate the port and select it manually.

If you have an SC485 serial port RS485 adapter, you will have to examine the connection on your computer or consult the owner's manual to determine which port it is plugged into. It is usually Comm 1 or Comm 2.

If you have a USB485 or USB485B serial port adapter, use the following procedure to find the communications port.

Click **start ► My Computer ► View System Information** and you should see a System Properties window like this one:

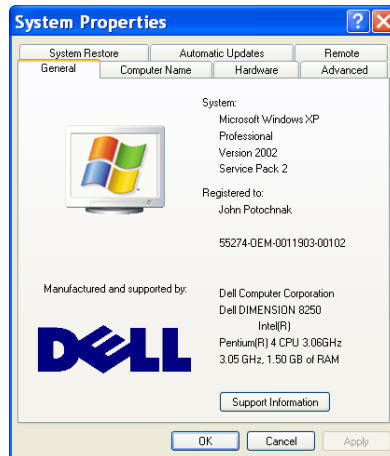

Click the *Hardware* tab and then the *Device Manager* button. You should see a *Device Manager* window like this one:

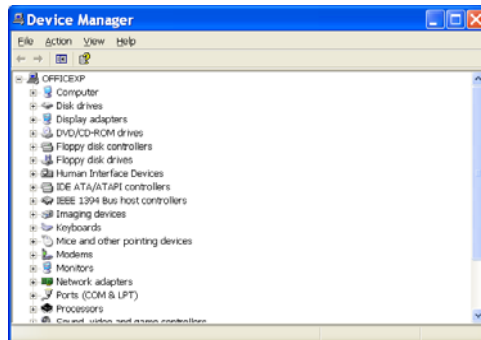

Scroll down and expand “Ports (COM & LPT).” You should see a “USB Serial Port (COMn).” This is your LOR communications port. Use the *Manual Select* drop down menu in the Hardware Utility to select this port. Proceed with your testing.

### ***Refresh does not find the controller***

You have previously: successfully configured the comm port, manually selected the comm port or

used another controller to Autoconfigure the comm port. In other words, you’re sure the RS485 adapter has been properly installed and is working. If this is not the case, consult the *Configuring the Communications Port* section.

When the controller is powered up but no data cable is connected to it, the Status LED should be blinking. This means that the controller is working, but is not in communication with a Show Director or PC. If the Hardware Utility is running, the RS485 adapter is properly configured and you attach a cable from the RS485 adapter to the controller, this Status LED should go to steady on. If this is not the case, then either the RS485 adapter is not properly installed, the Hardware Utility is not running or some component is broken.

If the light does go steady on, then manually type the Unit ID in hex into the box to the right of the *Refresh* button in the Hardware Utility. Connect some lights to the controller and try clicking the ‘On’ radio button in the “Test Unit’s Operation’ section. If the lights come on, your controller is working. If no good at this point, contact LOR support.

### ***CTB-16D Status LED not Blinking***

If your controller has no data cable connected and you plug in the power cord(s) and turn on the power switch, the Status LED should be blinking. If this is not the case, check the outlet for power with a lamp that is known to be working. Check the right fuse and replace if bad.

**Channel 9-16 OK, Channels 1-8 No Good**

Channels 1-8 don't work: Check the left fuse, replace if bad. Make sure the left power cord is plugged into a working outlet – test it with a known good lamp.

**Specifications and Features**

Specifications	Features
<ul style="list-style-type: none"> <li>• <b>Channel Capacity:</b> 8 amps per channel (16 amp triacs are used.)</li> <li>• <b>Controller Capacity:</b> 15 or 20 amps - single power feed, 30 or 40 amps – dual power feed.</li> <li>• <b>Isolation:</b> Opto isolators are used to isolate high and low voltage sides. Triacs are isolated. Parts are UL listed.</li> <li>• <b>Supply Voltage:</b> 120/240 VAC 50/60 Hz</li> <li>• <b>Power Connections:</b> Screw Terminals</li> <li>• <b>Control Input:</b> RS485 via RJ45 or RJ11 jacks</li> <li>• <b>Dimensions:</b> With Heat Sinks: 9”w x 6 5/8”h x 2 1/8”d Without Heat Sinks: 8 1/2”w x 5 1/4”h x 1 1/2”d</li> </ul>	<ul style="list-style-type: none"> <li>• <b>Input:</b> Unit can monitor an input to start a sequence</li> <li>• <b>Unit IDs:</b> Up to 240 controllers. Up to 3,840 channels.</li> <li>• <b>Fading:</b> 256 levels used for smooth fading effects. Fades from 0.1 to 25 seconds.</li> <li>• <b>Dimming:</b> 100 levels (0%...100%)</li> <li>• <b>Effects:</b> Ramp, Fade, Intensity, Twinkle, Shimmer</li> <li>• <b>Sequences:</b> 5,000 command internal flash memory sequence store</li> <li>• <b>Presets:</b> High-burn and low-burn settings.</li> </ul>

## Warnings and Liability

**WARNING:** The CTB-16D can pose a dangerous electrical hazard if not used properly. Care should be taken to keep the CTB-16D dry. When the CTB-16D is directly connected to a PC via one of the RS485 adaptors, there is a direct electrical connection between the low voltage logic side of the CTB-16D and the PC. If the CTB-16D is physically damaged causing traces to short or the device is allowed to get wet either through direct contact with water or condensation, the logic side of the CTB-16D can receive direct 120/240VAC. In that case damage to any connected hardware such as a PC can occur.

**IN NO EVENT SHALL BUYER BE ENTITLED TO INCIDENTAL, CONSEQUENTIAL, OR SPECIAL DAMAGES, NOR SHALL LIGHT-ORAMA'S LIABILITY EXCEED THE PURCHASE PRICE OF THE GOODS.**

## Appendix A Hexadecimal to Decimal

Hex	Dec	Hex	Dec	Hex	Dec	Hex	Dec
01	01	3D	61	79	121	B5	181
02	02	3E	62	7A	122	B6	182
03	03	3F	63	7B	123	B7	183
04	04	40	64	7C	124	B8	184
05	05	41	65	7D	125	B9	185
06	06	42	66	7E	126	BA	186
07	07	43	67	7F	127	BB	187
08	08	44	68	80	128	BC	188
09	09	45	69	81	129	BD	189
0A	10	46	70	82	130	BE	190
0B	11	47	72	83	131	BF	191
0C	12	48	72	84	132	C0	192
0D	13	49	73	85	133	C1	193
0E	14	4A	74	86	134	C2	194
0F	15	4B	75	87	135	C3	195
10	16	4C	76	88	136	C4	196
11	17	4D	77	89	137	C5	197
12	18	4E	78	8A	138	C6	198
13	19	4F	79	8B	139	C7	199
14	20	50	80	8C	140	C8	200
15	21	51	81	8D	141	C9	201
16	22	52	82	8E	142	CA	202
17	23	53	83	9F	143	CB	203
18	24	54	84	90	144	CC	204
19	25	55	85	91	145	CD	205
1A	26	56	86	92	146	CE	206
1B	27	57	87	93	147	CF	207
1C	28	58	88	94	147	D0	208
1D	29	59	89	95	147	D1	209

CTB-16D

1E	30	5A	90	96	150	D2	210
1F	31	5B	91	97	151	D3	211
20	32	5C	92	98	152	D4	212
21	33	5D	93	99	153	D5	213
22	34	5E	94	9A	154	D6	214
23	35	5F	95	9B	155	D7	215
24	36	60	96	9C	156	D8	216
25	37	61	97	9D	157	D9	217
26	38	62	98	9E	158	DA	218
27	39	63	99	9F	159	DB	219
28	40	64	100	A0	160	DC	220
29	41	65	101	A1	161	DD	221
2A	42	66	102	A2	162	DE	222
2B	43	67	103	A3	163	DF	223
2C	44	68	104	A4	164	E0	224
2D	45	69	105	A5	165	E1	225
2E	46	6A	106	A6	166	E2	226
2F	47	6B	107	A7	167	E3	227
30	48	6C	108	A8	168	E4	228
31	49	6D	109	A9	168	E5	229
32	50	6E	110	AA	170	E6	230
33	51	6F	111	AB	171	E7	231
34	52	70	112	AC	172	E8	232
35	53	71	113	AD	173	E9	233
36	54	72	114	AE	174	EA	234
37	55	73	115	AF	175	EB	235
38	56	74	116	B0	176	EC	236
39	57	75	117	B1	177	ED	237
3A	58	76	118	B2	178	EE	238
3B	59	77	119	B3	179	EF	239
3C	60	78	120	B4	180	F0	240

Light-O-Rama, Inc.  
 Tel: (518) 539-9000  
 Fax: (518) 538-0067  
 info@lightorama.com