

# Light-O-Rama



***LOR160xW g3***

## **Computerized Light Controller**

Generation 3 User Manual

October 21, 2011

V3.00

Copyright © Light O Rama, Inc. 2006-2011

# Table of Contents

Introduction .....	5	Assigning a Lighting Curve .....	27
What's in the Box .....	7	Input Header .....	28
Safety Considerations .....	7	Resetting the Controller .....	28
LOR160xW Component Locations .....	8	Stand Alone Speed Control .....	29
Figure 1 .....	8	Testing with the Hardware Utility .....	29
Quick Start Guide .....	9	Installing LOR Software .....	30
Connecting Up the LOR160xW .....	11	Connecting Controller-to-PC Data Cable .....	30
Connecting to a PC .....	11	Configuring the Communications Port .....	31
Connecting to an LOR1602MP3 .....	12	Setting the Unit ID with Software .....	33
Connecting to a Show Director .....	13	Creating A Sequence .....	35
Connecting to another Controller .....	13	Figure 2 .....	35
Creating a Show .....	14	Stand Alone Operation .....	40
Creating a Show (Full Capabilities) .....	14	Triggering a Stand-Alone Sequence .....	41
Power Considerations .....	15	Power On Mode .....	41
LOR1600W .....	15	Input Control Mode .....	41
LOR1602W .....	15	Troubleshooting .....	41
3-Phase Power .....	16	Autoconfigure does not find COM Port .....	41
Christmas Light Power Consumptions .....	17	Refresh does not find the controller .....	43
Lighting Curves .....	17	LOR160xW Status Display Blank .....	44
Configuring Lighting Curves .....	19	Channel 9-16 OK, Channels 1-8 No Good .....	44
Setting Multiple Channels in a Group .....	22	Warnings and Liability .....	45
Setting Individual Channels .....	22	Appendix A Hexadecimal to Decimal .....	46
Example .....	22	Specifications .....	48
Hardware Description .....	24		
Status Display .....	24		
Idle: .....	24		
Connected to LOR Network: .....	25		
Connected to DMX Universe: .....	25		
Loading Firmware: .....	25		
Resetting: .....	25		
Running a Standalone Sequence: .....	25		
Assigning a DMX Address .....	26		
Assigning a Unit ID .....	26		

## Introduction

The Light O Rama (LOR) LOR1600Wg3 and LOR1602Wg3 are 16 channel computerized lighting controllers. The “g3” indicates that they are the third generation in the model line. The LOR1600W is a single power cord 15 amp controller. The LOR1602W is a dual power cord 30 amp controller.

These controllers are designed to control incandescent and line voltage LED lighting. They operate on 120 VAC (240 VAC models are available), 50/60 Hz. The 30 amp configuration can control approximately 9,000 incandescent mini-lights or 70,000 LED mini-lights or some combination of both.

These controllers include “ghost loads” which drain off charge to prevent low brightness LED glow when LEDs should be off. The “ghost loads” also permit smoother LED fading.

These controllers use higher reliability output components than the previous generation. These components are more tolerant of overloads and even survive some direct short circuit situations.

These controllers provide greater accessory power than previous LOR controllers. This additional power is necessary for future accessories.

They understand both LOR and DMX protocols.

The g3 firmware included with these controllers has individual channel lighting curves for smooth, glitch-free dimming and effects with LED lighting. This firmware also increases the number of brightness

steps from 250 to 1000 for smoother fading with LEDs.

As with all LOR controllers, the firmware is field upgradeable so you are guaranteed compatibility with future LOR hardware and software products.

These controllers are components in the *Showtime Commercial Line* of LOR products. They carry the ETL seal certifying that they meet UL 508 safety standards. They are housed in weatherproof, powder-coated steel enclosures. They are microprocessor based, intelligent controllers that can perform a number of lighting effects including dimming, fading, shimmering and twinkling. They can be daisy-chained with any mix of LOR controllers up to the maximum of 240 controllers.

Sample uses:

- Daisy chained off of an LOR1602MP3 Show-in-a-Box lighting controller with a built in Show Director
- Connected to your PC running the LOR Showtime Windows software
- Connected to one of LOR's Show Directors (DC-MP3 or mDM-MP3)
- Running a standalone set of commands loaded into the controller's flash memory
- Daisy chained off of another controller that is either running stand alone or getting its commands from one of the other sources listed above

The LOR160xW lighting controller circuit board is the same one sold in the *Components Line* of products as the CTB32LDg3 16/32 Channel

Controlled Triac Board (Deluxe) with heavy duty heat sink.

To allow your PC to communicate with this controller, you will need one of Light O Rama's RS485 adapters. When you purchase the Generic Starter Package, you get the LOR Showtime Software, a 10' Cat5e network cable and you will be given a choice of two types of USB RS485 adapters or a serial port RS485 adapter. Choose the adapter appropriate for your PC/laptop. The RS485 adapter will allow you to connect your PC/laptop via the Cat5e cable to your lighting controller.

## What's in the Box

In addition to your LOR160xW lighting controller you will also receive this LOR160xW user manual

The latest copy of the manual is available at [www.lightorama.com](http://www.lightorama.com) ► *Support* ► *User Manuals* section.

## Safety Considerations

The metal enclosure is weather resistant provided that the LOR160xW is mounted with the wires pointing downward. The pigtail outlets must be at least one foot off the ground. Keep the unit away from heavy splashing water and forced water flows such as from irrigation sprinklers.

Anchor communication cables using wire ties to a stable point such as the top mounting tab. Place a small piece of duct tape over the hole in the bottom of the unit once communication cables have been installed. Do not seal entire unit with tape. It needs to breath.

To connect the communications link, set the Unit ID, access the on/off switch or change the fuses, you must remove the front cover. **The unit is not weatherproof when this cover is removed.**

## LOR160xW Component Locations

Remove the two screws from the bottom of the front cover, pull down and lift off the cover. Refer to the following figure for component locations.

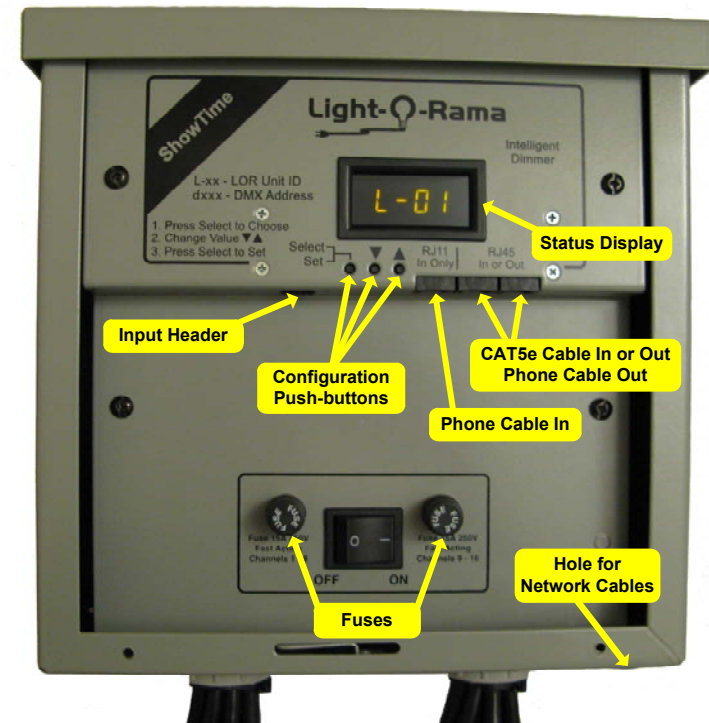

**Figure 1**

The controller is shipped set to Unit ID 1 for LOR networks and DMX address 1 in the DMX universe.

## Quick Start Guide

This section gets you going in the common case where you bought the SPK-ST Generic Start Kit (Showtime Windows software, RS485 adapter and Cat5e connecting cable.) You will be using the Showtime software on your PC to direct your LOR160xW lighting controller.

If you have problems, see the detailed sections: *Connecting up the LOR160xW* and *Testing with the Hardware Utility*.

- (1) Install the Showtime PC software.
- (2) Install the RS485 adapter. If you have the SC485 serial port adapter, just plug it into a serial port on the back of your PC. If you have one of the USB adapters (USB485 or USB485B) follow the directions that came with the adapter.
- (3) Remove the two cover screws from the LOR160xW and lift off the cover.
- (4) Plug the Cat5e cable into the RS485 adapter connected to your PC and into either of the large RJ45 jacks on the controller.
- (5) Plug in the LOR160xW power cord(s) and turn it on, the Status Display will rotate through the Unit ID, DMX address and “no conn,” meaning no connection to a PC or Show Director.
- (6) Start the Light O Rama Control Panel: click **start** ► **All Programs** ► **Light-O-Rama** ► **Light-O-Rama Control Panel**. Answer OK to any initialization boxes. There will be a light bulb with a red halo on the right side of the task bar at the

bottom of the screen. Right-click the light bulb and select *Hardware Utility* (HWU) from the menu. You will see this window:

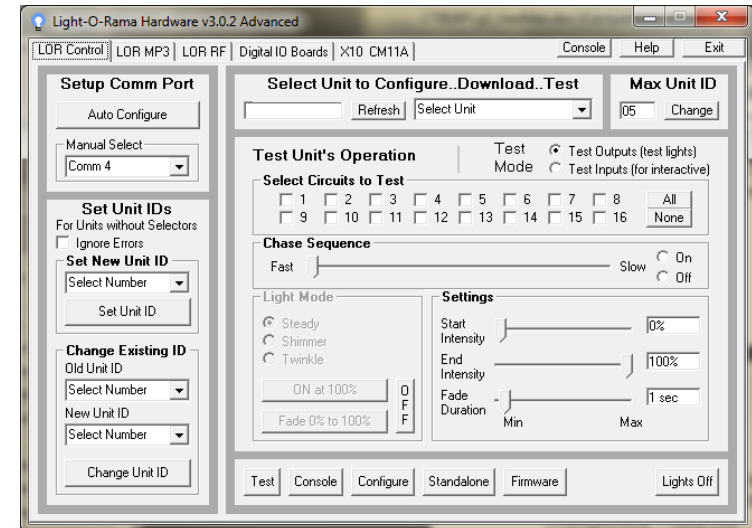

- (7) Click the *Autoconfigure* button on the upper left. The HWU will search for the Light O Rama port.

Tip: Under “Max Units” on the upper right, click the *Change* button and move the slider to select 10 units. This will cut down the scan time because the HWU will not have to scan for 240 controllers. Click OK.

- (8) Click the *Refresh* button at the center top. The HWU will scan for all connected controllers. Your controller will appear in the drop down menu to the right of the *Refresh* button.
- (9) Plug some lights into the LOR160xW and use the “Test Unit’s Operation” section to turn on lights, etc.

If you would like to create a simple sequence, see the *Creating a Sequence* section.

## Connecting Up the LOR160xW

In order to use your LOR160xW, you must connect it to a show director, Windows PC or run it in standalone mode (see the *Stand Alone Operation* section.)

### Connecting to a PC

You will need the following to connect your LOR160xW lighting controller to a PC:

- Showtime Windows Software
- RS485 Adapter
- CAT5e LAN cable or phone cable
- Your LOR160xW
- Windows PC running XP, Vista or Win7

The first three items are available in the LOR SPK-ST Generic Starter Package. [www.lightorama.com](http://www.lightorama.com) ► *On-line Store* ► *Showtime Products*. You will have to choose an RS485 adapter type. It's best to go with the USB485 if you have no intention of going wireless from your PC to the controller. If wireless is desired, get the USB485B.

The following diagram shows how the pieces fit together:

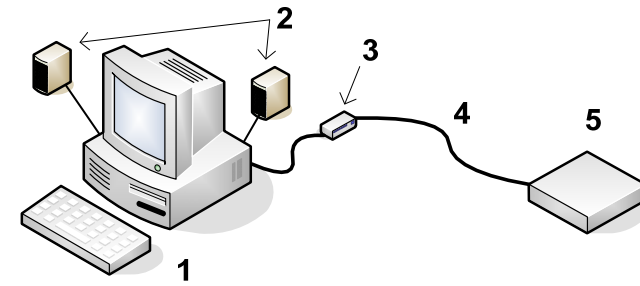

1. Your PC running the Showtime Windows Software
2. Your PC speakers to play the music
3. RS485 Adapter to convert short distance USB to long distance RS485
4. Phone or CAT5e LAN cable
5. LOR160xW lighting controller

If your USB adapter has more than one RJ45 jack, you can use either.

If you are using phone cable to connect the RS485 adapter to your controller, make sure you use the "RJ11 In Only" jack on the LOR160xW. See Figure 1. If you are using CAT5e LAN cable, you can use either of the "RJ45 In or Out" jacks on the controller.

### Connecting to an LOR1602MP3

You will need the following to connect your LOR160xW lighting controller to a LOR1602MP3 "Show in a Box Controller":

- LOR1602MP3
- Phone or CAT5e LAN cable
- Your LOR160xW

If you are using phone cable to connect the LOR1602MP3 to the LOR160xW, make sure you

use either one of the “RJ45 In or Out” jacks on the LOR1602MP3 and the “RJ11 In Only” jack on the LOR160xW. See Figure 1.

If you are using CAT5e LAN cable, you can use either of the “RJ45 In or Out” jacks on either device. See Figure 1.

### **Connecting to a Show Director**

You will need the following to connect your LOR160xW lighting controller to a Show Director:

- mDM-MP3 or DC-MP3 Show Director
- Phone or CAT5e LAN cable
- Your LOR160xW

If you are using phone cable to connect a Show Director to the LOR160xW, you can use either jack on the DC-MP3. Make sure you use the “RJ11 In Only” jack on the LOR160xW. See Figure 1.

If you are using CAT5e LAN cable, you can use either jack on the DC-MP3 and either of the “RJ45 In or Out” jacks on the LOR160xW. See Figure 1.

The cable connecting a show director to the controller should be 50’ or less in length. Longer cables may result in a voltage drop causing erratic operation of the show director.

### **Connecting to another Controller**

If you are using phone cable to connect the controllers, always go from either of the “RJ45 In or Out” jacks on one controller to the “RJ11 In Only” jack on other controller. See figure 1.

If you are using CAT5e LAN cable, you can go from either “RJ45 In or Out” jack on one controller to

either “RJ45 In or Out” jack on the other controller. See Figure 1.

## **Creating a Show**

The simplest way to create a show is to purchase pre-made musical sequences from LOR. These can be purchased in sets on a CD, or individually via download from the LOR website. To see the currently available musical sequences, go to [www.lightorama.com](http://www.lightorama.com) ► *On-line Store* ► *Musical Sequences* button (left.)

You can also create the sequences yourself using the Showtime Windows software. See the *Creating a Sequence* section.

Once you have the sequences on your PC, the *Simple Show Builder* is the easiest way to arrange these sequences into a show and schedule the show.

The *Simple Show Builder* is accessed by right-clicking the LOR light bulb on the lower right of your screen and selecting *Simple Show Builder*. Follow the instructions on the screen to create your show. In a few simple screens, you will have arranged your musical sequences into a show and scheduled this show.

## **Creating a Show (Full Capabilities)**

If you are looking for more flexibility in your show, the following features not available with *Simple Show Builder*:

- More than one show
- More flexible scheduling

- Interactive shows

See the Showtime Windows software guide for more information on running shows from your PC using the Showtime Windows software.

See the DC-MP3 User Manual for more information on running shows with a DC-MP3 Show Director.

See the mDM-MP3 User Guide for more information on running shows with an mDM-MP3 miniDirector.

## Power Considerations

This section attempts a relatively simple answer to the question “How many lights can I use?”

### ***LOR1600W***

The LOR1600W has one power input cord and a total capacity of 15 amps.

The maximum current on a single channel is 8 amps. The maximum current for all channels is 15 amps. So you have to divide up your lights on the 16 channels so you don't exceed either of these two limits.

You could put 1 amp on 14 channels and 0.5 amps on 2 channels and that would be 15 amps. Or, you could put 0.5 amps on 14 channels, 8 amps on another channel and 0 amps on the last channel and that would be 15 amps.

### ***LOR1602W***

The LOR1602W has two power input cords and a total capacity 30 amps. The left input cord powers

channels 1-8. The right power input cord powers channels 9-16 and the controller's microcomputer.

If you plug both power cords into one circuit, then the controller would have at most 20 amps available, but more likely, the circuit is a 15 amp circuit, so that's all you'll have available. If you can plug the two power cords into separate circuits, then the full 30 amp capacity of the controller will be available.

We will talk about only the right channels for now. The same discussion applies to the left channels.

The maximum current on a single channel is 8 amps. The maximum current for all right channels is 15 amps. So you have to divide up your lights on the 8 channels so you don't exceed these two limits.

You could put 1 amp on 7 channels and 8 amps on the last one and that would be 15 amps. Or, you could put 2 amps on 6 channels, 1 amp on another channel and 2 amps on the last channel and that would be 15 amps.

The same computation applies to the left bank of channels. Remember, if the controller is plugged into only one circuit in your house, then both the left and right banks' total current must not exceed what that circuit can supply.

### **3-Phase Power**

The LOR1602Wg3 has separate sensing for the power phase on its two power input cords. This means that power phase does not matter and the controller can be plugged into two different phases in three phase commercial environments.

### **Christmas Light Power Consumptions**

The following table gives the approximate current consumption for various types of Christmas lights.

Description	Lights/string	Amps/string
Mini-lights	50	0.17
Mini-lights	100	0.33
C7 bulbs	25	1.04
C9 bulbs	25	1.5
100 watt bulb	1	0.75
150 floodlight	1	1.25
LED mini-lights	70	0.03
LED C6 or C7	25	0.02

If you put six sets of 100 mini-lights on one channel, that would be  $6 * 0.33 =$  about 2 amps. If you put six sets of 70 LED mini-lights on one channel, that would be  $6 * 0.03 =$  about 0.18 amps. You can see that you can have a lot of LEDs with very little power.

Make a chart of all the lights you want to connect to the controller's channels and then work out the numbers to see if you hit any limits.

### **Lighting Curves**

The g3 firmware supports lighting curves. These are used to allow different types of lights to behave similarly when dimming. LEDs tend to go from off to full brightness over a much narrower range of voltages than incandescent lights. This means that a fade going from 0 to 100% voltage with an

incandescent light will not produce the same results with LED lights. The LED lights will come on later and reach full brightness sooner than incandescent lights.

There is a built-in Standard curve for incandescent lights which behaves as a simple, linear 0 to 100% voltage provider. This is the behavior seen with previous versions of the firmware and most DMX dimmer packs.

There is a built-in On/Off curve. This on/off 'curve' is used on a channel where the connected devices do not tolerate dimming, for example, the air blower motors in inflatables. Setting a channel configured for on/off operation to any intensity 50% or greater results in 100% intensity or 'on'. Intensities below 50% result in the channel being off.

Finally, a LED curve is provided which is the average for various LED colors and dimmable power supply configurations. This curve is provided with the software, so if you choose to change it you can recover the original. It is custom curve 1.

The g3 firmware permits the controller to accept up to eight downloaded, custom curves.

Each channel is configured with its own curve from the ten possible curves the controller may have available.

The default location for curve files is  
 ...Light-O-Rama\DimmingCurves

The curve file names are LOR-Curve01.ldc through LOR-Curve08.ldc.

A curve file is a list of comma delimited numbers with as many numbers per line as you like. Text on a line preceded by '#' is treated as a comment.

There are 1024 numbers in a curve file. The first number represents off and the last full brightness. A number in the curve file is a value between 0 and 1023. The curve files map into the LOR brightness world for which LOR will provide a conversion utility.

## Configuring Lighting Curves

Each channel on the controller is assigned a lighting curve. Initially, all channels are configured with the Standard curve. See the *Lighting Curves* section for more information on what curves are and which curves come with the controller.

The Hardware Utility is used to read current curve information from the controller, download new curves to the controller and associate curves with the output channels.

Start the Hardware Utility (see *the Assigning a Unit ID* section).

In the *Max Units* section of the Hardware Utility window, click the *Change* button. Move the slider in the *Change Maximum Units* box so that the Max Units is set to 10 (or the maximum number of controllers you have configured.) This will limit the search for controllers to the first 10 unit IDs, otherwise 240 controllers would be searched for – taking a long time. Click the *Save* button.

Click the “Refresh” button to find your controller(s). Select a controller from the drop down menu to the right of the Refresh button. Then click the

“Configure” button at the bottom of the window. You will see this window:

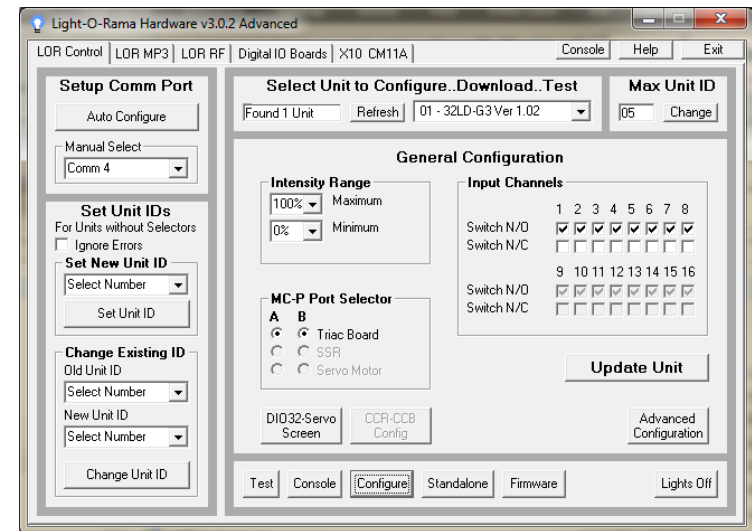

Click the “Advanced Configuration” button on the lower right. The Hardware Utility will read the current curve information from the controller, find the curve files on your PC (if any) and display this window:

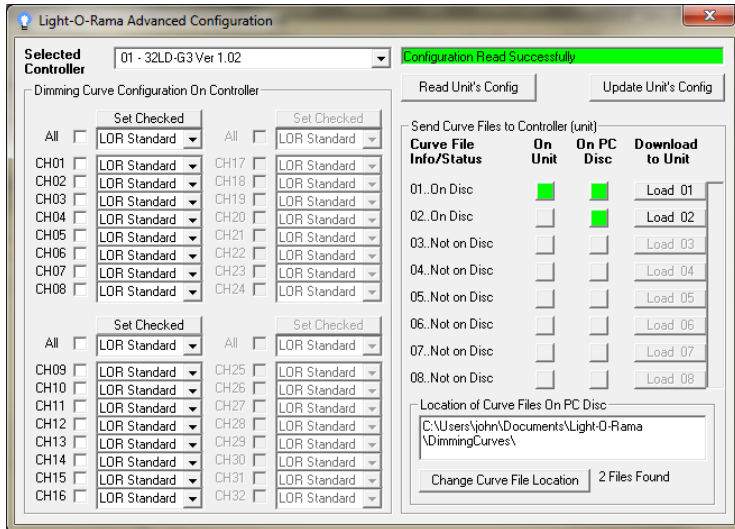

This initial configuration shows all channels configured for the Standard curve, also shown is one custom curve file loaded into the controller and two custom curve files located on the PC disk.

The LOR160xWg3 controllers are 16 channel controllers so channels 17 through 32 are grayed out.

To transfer a new curve from the PC to the controller or update an existing curve on the controller from the PC, click the appropriate “Load *nn*” button. The curve file on disk will be transferred to the controller. The vertical progress bar to the right of the “Load *nn*” buttons will indicate percent transferred to controller.

The *Read Unit's Config* button will ask the controller for its channel to curve file mapping and show which custom curves are loaded into the controller.

### Setting Multiple Channels in a Group

You can change the curve association for multiple channels in channel group 1-8 or channel group 9-16 using the “All” row above that channel group. If you check the “All” box, then all channels in that 8 channel group will be affected. If you only want to change some of the channels in the group, check their individual check boxes. Then use the drop down menu in the “All” row to select the curve for the checked channels and click the *Set Checked* button. Those channels will be changed to the curve selected. Finally, click the *Update Unit's Config* button to send the new curve configuration to the controller.

### Setting Individual Channels

Do not check the “All” box, but do check the boxes to the left of the channels for which you want to change curves. Then use the drop down menu next to the checked box to select the curve you want for that channel. Finally, click the *Update Unit's Config* button to send the new curve configuration to the controller.

Note: If you configure a channel for a curve that does not exist in the controller, the Standard curve will be used.

### Example

In the following example, channels 3 and 4 are being set to custom curve 01 and channels 15 and 16 are being set as On/Off only channels. The check boxes for channels 3, 4, 15 and 16 are checked and the drop down menus have been used to select the desired curves:

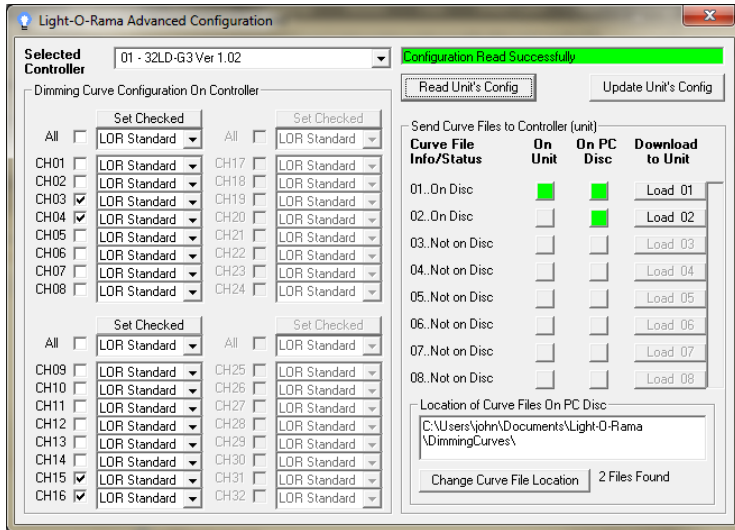

Clicking the *Update Unit's Config* button sends the new curve configuration to the controller. The controller is updated and the text in the upper right box changes to indicate this:

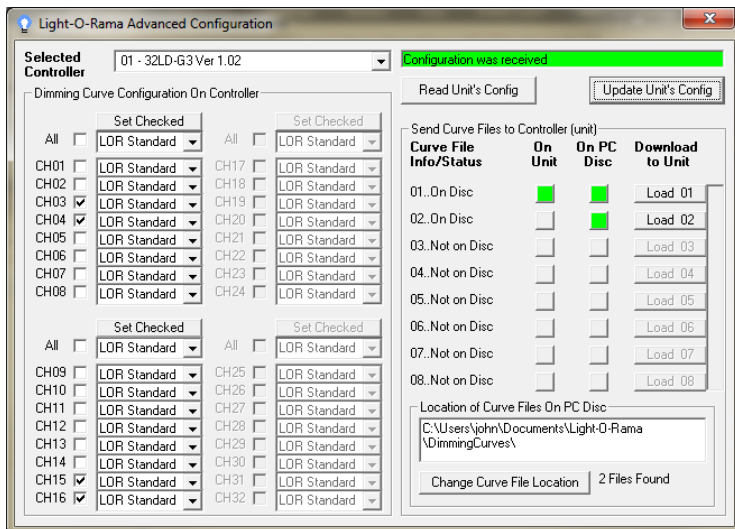

If you use the controller's Status Display (see *Assigning a Lighting Curve* in the *Status Display* section) to check the lighting curves you will see that the controller is now using Hardware Utility curves as indicated by "C-HS" meaning **Hardware Utility Settings**:



## Hardware Description

### Status Display

Idle:

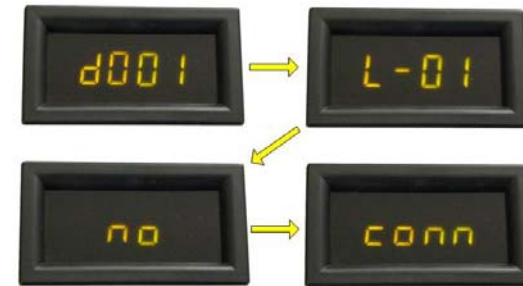

The Status Display rotates through four messages when the controller is powered but not connected to a controlling PC or Show Director and is not running a stand-alone sequence. It is displaying the LOR Unit ID, the DMX Universe address and "no conn" meaning no connection to any LOR network or DMX universe."

**Connected to LOR Network:**

The display steadily shows “L-01,” meaning the controller is set to LOR Unit ID 01.

**Connected to DMX Universe:**

The display steadily shows “d001” meaning the controller is set to DMX address 001.

**Loading Firmware:****Resetting:**

“0000” is displayed for a couple of seconds while the controller is resetting. See the *Resetting the Controller* section for more information.

**Running a Standalone Sequence:****Assigning a DMX Address**

To set the DMX Address, press the Select/Set button until the status display flashes “dnnn” where nnn is the current DMX address. Use the ▼ and ▲ buttons to select the DMX address you want and then press the Select/Set button to save the DMX address. You can hold the ▼ or ▲ button down to scroll through addresses.

You can also set the DMX Address with the Hardware Utility. In this case you set the Unit ID which sets the DMX address to  $((\text{Unit ID}) - 1) * 16 + 1$ . See the *Setting the Unit ID with Software* section.

A cable that plugs into one of the controller’s RJ45 jacks and terminates with in a male XLR-3 plug is available here: [www.lightorama.com](http://www.lightorama.com) ► On-line Store ► Accessories ► RJ-45 to XLR 3-Pin Male

**Assigning a Unit ID**

To set the Unit ID, press the Select/Set button until the status display flashes “L-nn” where nn is the current Unit ID. Use the ▼ and ▲ buttons to select the Unit ID you want and then press the Select/Set button to save the Unit ID. You can hold the ▼ or ▲ button down to scroll through IDs.

You can also set the Unit ID with the Hardware Utility. This will also set the DMX address to  $((\text{Unit ID}) - 1) * 16 + 1$ . See the *Setting the Unit ID with Software* section.

Each LOR light controller used in a network must have a unique ID assigned. [If two controllers are given the same unit ID, then they will both perform the same effects.] Every channel that you control in

a sequence (A Sequence is a set of lighting controller commands constructed using the Showtime Windows software) has to identify a particular output circuit on a particular lighting controller (Unit.)

For example, in a sequence that you construct, a channel you call “Front door” may be assigned to Unit ID 03 circuit 10. Because the controllers are daisy chained together, every controller sees every command sent but Unit 03 will only react to commands that are marked “for Unit 03.”

See Appendix A for a conversion of Hexadecimal controller unit IDs set with the Status Display and their decimal equivalents.

### Assigning a Lighting Curve

You can only assign all channels of the controller to one lighting curve through the status display. You must use the Hardware Utility program to assign individual channels to different curves. See the *Lighting Curves* and *Assigning Lighting Curves* sections for more information on curves.

To adjust lighting curves from the Status Display, press the Select/Set button until the display shows “C-xx.” Eg:



Then use the ▼/▲ buttons to select one of the following values:

- C-S Standard lighting curve for all channels
- C-Cn Lighting curve n for all channels

- C-HS Hardware Utility program Set curves
- C-0F On/Off lighting curve for all channels

Press the Set button to save your choice.

### Input Header

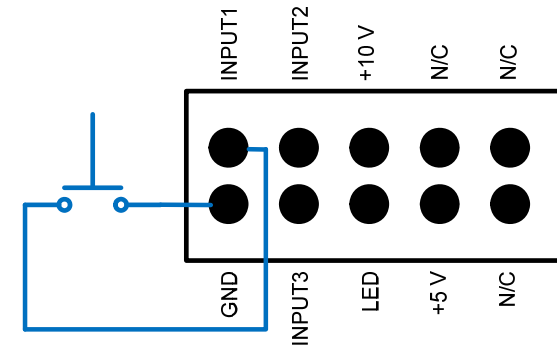

This figure shows the Input Header that is to the left and below the Select/Set button. See Figure 1. You can connect switches here to trigger standalone sequences or provide trigger events for interactive shows. See the *Stand Alone Operation* section for more information.

Switches are simple normally open or normally closed types. No voltages may be applied to the switch inputs. You may take up to 500ma total from the 5 vdc and 9 vdc power supplies to power devices like motion sensors.

### Resetting the Controller

To reset the controller, press both the ▼ and ▲ buttons simultaneously and turn the controller power on. The display will show “0000.” Release the ▼ and ▲ buttons when you see the “0000.” The

controller will go into normal operation mode in about two seconds.

### **Stand Alone Speed Control**

You can set the speed at which a standalone sequence is run. See the *Stand Alone Operation* section for more information on standalone sequences.

You can only set the standalone speed if a standalone sequence is loaded into the controller. Press the Select/Set button until the status display flashes “SPnn” where nn is the current speed:



The speed is a number between 00 and 13. When set to “06,” one second of real time equals one second of sequence time. This means the sequence runs at the same speed as it would be run by a Show Director or your PC. Lower numbers slow the sequence down.

SP00 is approximately 2.5 seconds/second sequence time. SP13 is approximately 0.33 seconds/second of sequence time.

Use the ▼ and ▲ buttons to change the speed. To save the new speed, let the display time out or press Select/Set.

### **Testing with the Hardware Utility**

Use this section to learn how to connect your controller to your PC. If you have already installed

the RS485 adapter and verified its operation with another controller, you can skip to the *Creating A Sequence* section.

Once power has been supplied to the LOR160xW the Status Display will rotate through the “Idle” messages – see the *Status Display* section. This indicates that the Unit is functioning and that there is no communication. Once communication with a PC, Show Director or another controller is established, the Status Display will stop rotating through the “Idle” messages and steadily show its Unit ID.

### **Installing LOR Software**

You must have the LOR ShowTime software installed on your PC to proceed. Follow the instructions that came with the software to install it.

### **Connecting Controller-to-PC Data Cable**

If you want to experiment with the lighting controller using the LOR Windows Software, you will have to install an RS485 adapter so you can talk to it from your PC.

If you have an SC485 (PC serial port adapter, shown on the left in the following picture), you need only plug it into an available PC 9-pin serial port. The cable from this serial adapter to the controller is limited to 100’ or less.



If you have one of the USB adapters (shown in the previous picture on the center and right), follow the installation instructions that came with the adapter to install it. If your adapter has two RJ45 jacks, you can use either.

If you are using telephone cable to connect your controller to the RS485 adapter, plug one end of the phone cable into the adapter and the other end of the cable into the *RJ11 In Only* jack shown in Figure 1.

If you are using Cat5e LAN cable to connect your controller to the RS485 adapter, plug one end of the data cable into the adapter and the other end into either of the *RJ45 In or Out* jacks shown in Figure 1.

### Configuring the Communications Port

First start the Showtime software control panel by clicking **start ► All Programs ► Light-O-Rama ► Light-O-Rama Control Panel**. There will be a light bulb with a red halo on the right side of the task bar at the bottom of the screen. Right-click the light bulb and select *Hardware Utility* (HWU) from the menu. You will see this window:

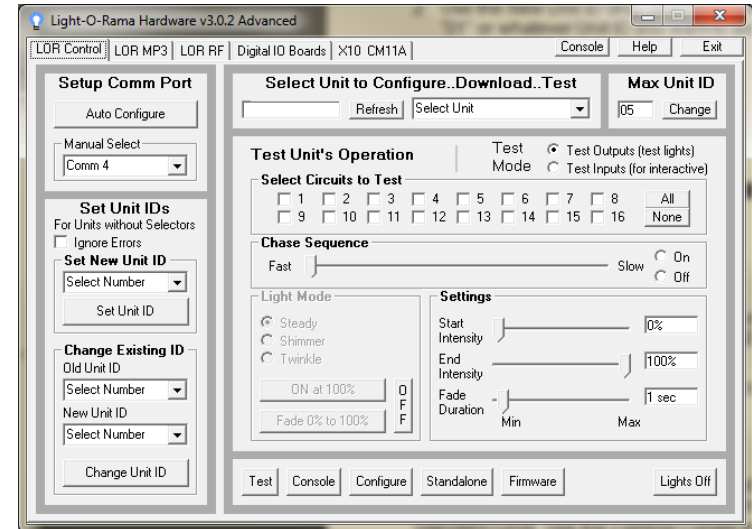

With your controller powered up and cabled to your PC, click the *Auto Configure* button on the top left. The HWU will pop up a window asking you to make sure everything is connected, click OK. It will then search through all ports on your PC looking for the port being used by Light O Rama and you will see this window like this one:

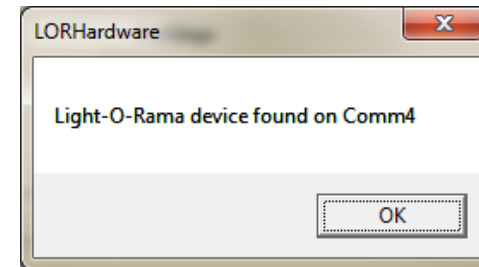

Click *OK*, your RS485 adapter has been located and is functioning properly. This will also make this port available to other LOR software, like the Sequence Editor which is used to create your

lighting control sequences. See the *Troubleshooting* section if you have problems.

Tip: Under “Max Units” on the upper right, click the *Change* button and move the slider to select 10 units. This will cut down the scan time because the HWU will not have to scan for 240 controllers. Click OK.

Click the *Refresh* button (center top of window) to have the Hardware Utility scan for all controllers attached to the PC. When it finishes, the drop down menu to the right of the *Refresh* button will list all controllers found. Use this menu to select your controller. See the *Troubleshooting* section if you have problems.

You can use the “Test Unit’s Operation” portion of the window to test the controller. Make sure you have some lights plugged into the controller and use the various options to test the lights.

This is a good time to experiment with different intensities, fade rates and chase speeds. This information will be useful if you want to create your own light shows.

### Setting the Unit ID with Software

If you have not installed the Light O Rama Windows Showtime Software, do it now.

Plug the LOR160xW power cord(s) into AC power and turn it on. The Status Display should rotate through the “Idle” messages – see the *Status Display* section. This means that the controller is waiting for the PC to talk to it. Connect the controller to your PC – see the *Connecting Controller-To-Pc Data Cable* section.

Start the Hardware Utility – click **start ► All Programs ► Light-O-Rama ► Light-O-Rama Control Panel**. There will be a light bulb with a red halo on the right side of the task bar at the bottom of the screen. Right-click the light bulb and select *Hardware Utility* from the menu. Make sure the *LOR Control* tab is selected. You will see the following window:

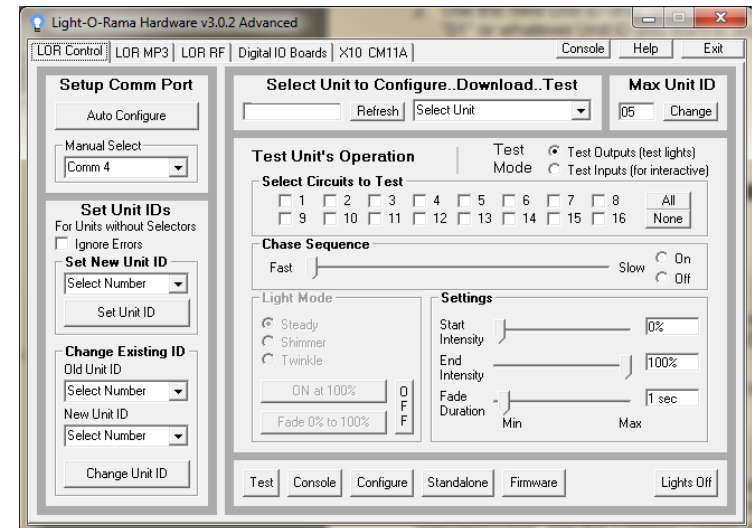

Click the *Auto Configure* button in the *Setup Comm Port* section. The Hardware Utility will search for the COM port that your RS485 adapter is plugged into and select it.

When assigning a unit ID, only one controller should be plugged into the RS485 adapter on the PC. Be sure you do not have more than one controller connected.

Steps to set/change unit ID:

1. In the *Change Existing ID* section, use the *Old Unit ID* drop down menu to select *Any Unit*, then

- click **OK** in the warning box for changing all unit IDs, there should only be one unit attached.
- Use the *New Unit ID* drop down menu to select "01" or whatever Unit ID you want to assign to the attached controller.
  - Click the *Change Unit ID* button to set your LOR160xW unit ID. You will see a *Unit ID Changed* box – click **OK**.

The DMX address is set to  $((\text{Unit ID}) - 1) * 16) + 1$ .

## Creating A Sequence

This section assumes that you have used previous sections to configure your controller and attach it to your PC. If you haven't done this, see the *Assigning a Unit ID* and *Testing with the Hardware Utility* sections.

The following screen shot is for later reference, it shows the Sequence Editor with the completed test sequence and labels for the functions used.

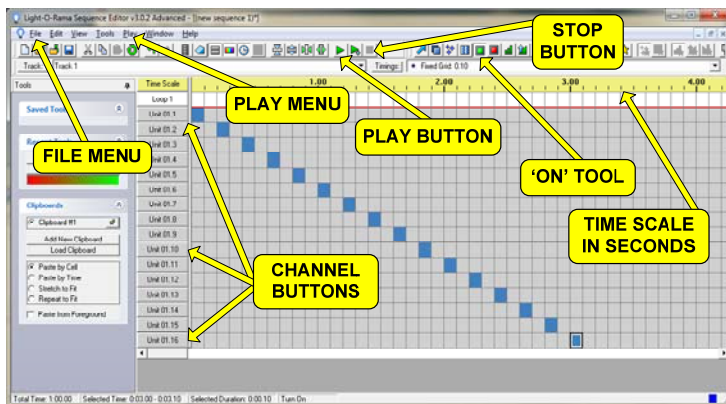
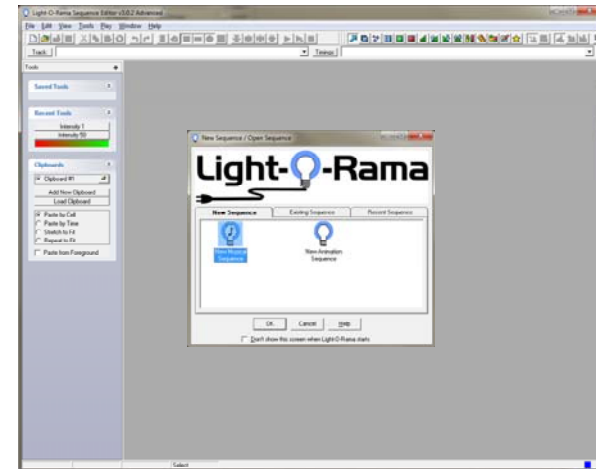

Figure 2

First start the Showtime software control panel if it is not already running by clicking **start ► All Programs ► Light-O-Rama ► Light-O-Rama Control Panel**. There will be a light bulb with a red halo at the bottom of the screen on the right or it will be in the pop-up menu accessible by clicking the up-arrow.

Stop the Hardware Utility if it is running because only one LOR program may use the communications port at a time. Right-click the light bulb and select *Sequence Editor* from the menu and you will see this window:



Click *New Animation Sequence* light bulb and click **OK**, you will see the following window:

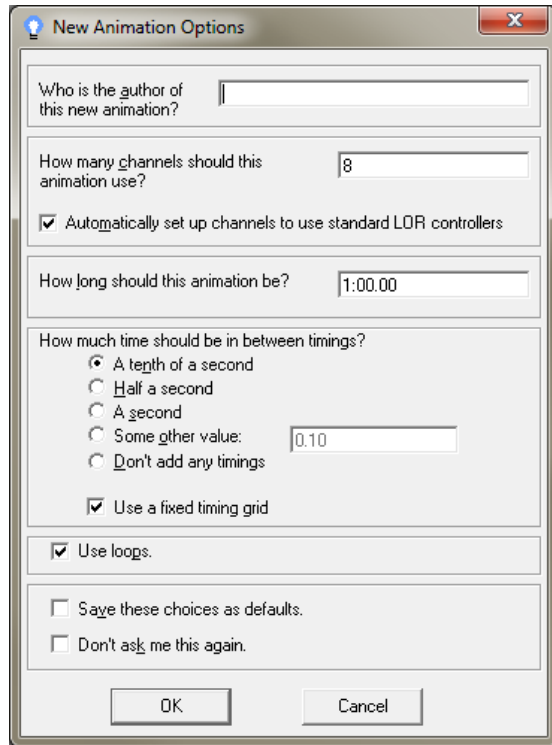

Set the number of channels to 16, the rest of the options can be left as is and click OK. You will see the following window:

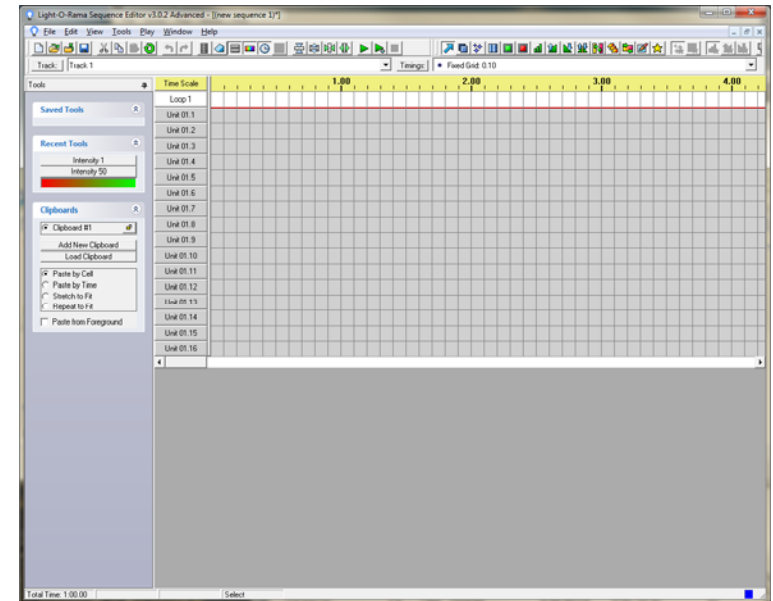

You now have a blank sequence grid with the channels configured.



The rows in this grid represent the circuits on the lighting controller. The “Unit 01.1” row is circuit 1, “Unit 01.2” is circuit 2, ... If you look at the output pigtails on the controller, you will see small number bands on each socket – these correspond to the grid rows now.

The columns in the grid represent time increasing to the right.

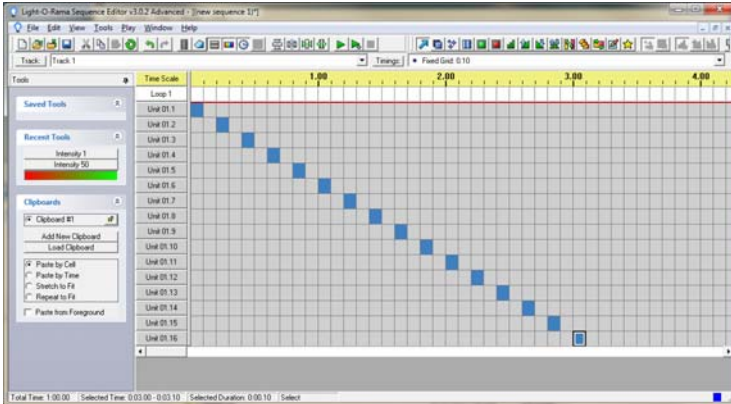
Refer back to Figure 2 if needed and click the ‘on’ tool . When you click it and then click in the grid, it will turn ‘on’ the lights for those circuits at the times you click. In the following example, I have clicked to turn each light on in sequence for a 10<sup>th</sup> of a second during the first 3.1 seconds of the sequence.



In the top tool bar, make sure *Control Lights* in the *Play* menu is checked. Refer back to Figure 2.

Clicking the green play button  in the tool bar will run your sequence. The red button  to the right of the play button is the stop button. The stop button will be grayed out  if a sequence is not playing. If you have lights plugged into the controller, this simple sequence will light them in circuit order. You have created your first sequence.

There are Quick Start Guides for creating animation (non-musical) and musical sequences, Flash Tutorials on this subject and much more at:

[www.lightorama.com](http://www.lightorama.com) ► **Support**

The following Wiki is also an excellent source of information on all things Light-O-Rama:

[www.lorwiki.com](http://www.lorwiki.com)

There is a very active and helpful group of people on the Light O Rama bulletin board:

[forums.lightorama.com](http://forums.lightorama.com)

There is also a very active and helpful user community on the Planet Christmas bulletin board:

[www.planetchristmas.com](http://www.planetchristmas.com)

## Stand Alone Operation

A standalone animation sequence (sequence with no accompanying audio) can be downloaded into the flash memory of the lighting controller.

This sequence can contain approximately 10,000 lighting commands. These commands can also be for controllers other than this controller, so this controller can direct a network of controllers. There are no restrictions on the types of LOR controllers in this network.

The sequence is designed and tested using the Showtime Software Sequence Editor. When you are happy with the sequence, save it and stop the Sequence Editor.

Start the Hardware Utility and click the *Refresh* button to find the LOR160xW. Use the drop down menu next to the *Refresh* button to select the controller.

Click the *Standalone* button at the bottom of the window. Select one of “Run when power is on,” “Input (norm open switch)” or “Input (norm closed switch.)” Click the *Send Trigger info to Unit* button.

Finally, Use the *Open* button to browse to your sequence and click the *Download* button.

You also use this screen to remove downloaded standalone sequences. You can also remove a

standalone sequence by resetting the controller, see the *Resetting the Controller* section.

## Triggering a Stand-Alone Sequence

In the *Hardware Utility*, when you download a standalone sequence, you can specify what trigger condition will be used to start that sequence. A standalone sequence can be triggered one of two ways: *Power on* and *Input Control*.

### Power On Mode

This means that the sequence will run anytime that power is supplied to the controller. You plug it in and it plays until you unplug it.

### Input Control Mode

This uses an input on the controller to determine when the sequence will run. When the input switch is on, the sequence will run one time and then check to see if the switch is still on. For more information on trigger conditions see the help for the *Hardware Utility*.

For information on how to connect the switch to the controller, see the *Input Header* section.

## Troubleshooting

### Autoconfigure does not find COM Port

If the automatic method of determining the communication port used by LOR does not work, you may be able to locate the port and select it manually.

If you have an SC485 serial port RS485 adapter, you will have to examine the connection on your computer or consult the owner's manual to determine which port it is plugged into. It is usually Comm1 or Comm2.

If you have a USB485 or USB485B serial port adapter, use the following procedure to find the communications port.

Click **start ► My Computer** or **Computer ► View System Information** or **System Properties** If there is a Hardware tab, click it. Then click "Device Manager." You should see a *Device Manager* window like this one:

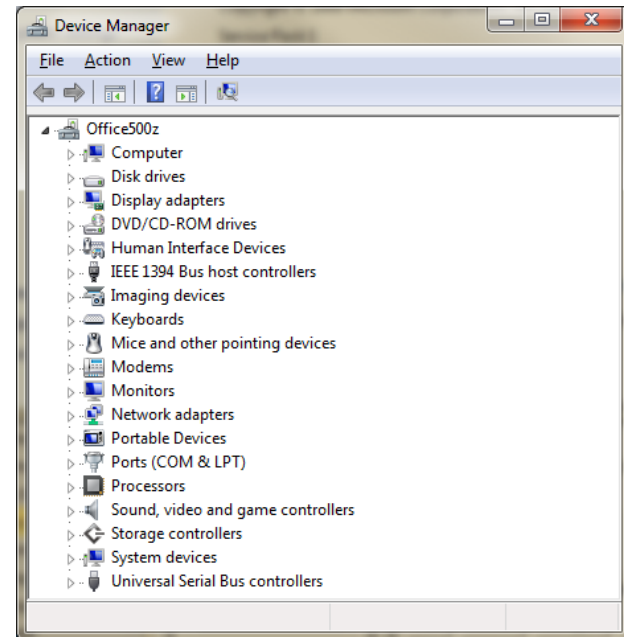

Scroll down and expand "Ports (COM & LPT)." You should see a "USB Serial Port (COMn)." This is your LOR communications port. Use the *Manual*

Select drop down menu in the Hardware Utility to select this port. Proceed with your testing.

***Refresh does not find the controller***

You have previously successfully configured the comm port, manually selected the comm port or used another controller to Autoconfigure the comm port. In other words, you're sure the RS485 adapter has been properly installed and is working. If this is not the case, consult the *Configuring the Communications Port* section.

When the controller is powered up but no data cable is connected to it, the Status Display should be rotating through "Idle" messages as described in the *Status Display* section. This means that the controller is working, but is not in communication with a Show Director or PC. If the Hardware Utility is running, the RS485 adapter is properly configured and you attach a cable from the RS485 adapter to the controller, this Status Display should go to steady display of "L-nn" where nn is the Unit ID. If this is not the case, then either the RS485 adapter is not properly installed, the Hardware Utility is not running or some component is broken.

If the display does display steady "L-nn," then manually type the Unit ID displayed into the box to the right of the *Refresh* button in the Hardware Utility. Connect some lights to the controller and try clicking the 'On at 100%' button in the "Test Unit's Operation" section. If the lights come on, your controller is working. If no good at this point, contact LOR support.

***LOR160xW Status Display Blank***

If your LOR160xW has no data cable connected and you plug in the power cord(s) and turn on the power switch, the Status Display should be rotating through the "idle" messages as described in the *Status Display* section. If this is not the case, check the outlet for power with a lamp that is known to be working. Check the right fuse (refer to Figure 1) and replace if bad.

***Channel 9-16 OK, Channels 1-8 No Good***

Channels 1-8 don't work: Refer to Figure 1. Check the left fuse for the LOR1600W and the LOR1602W, replace if bad. For the LOR1602W, make sure the left power cord is plugged into a working outlet – test it with a known good lamp.

## Warnings and Liability

**WARNING:** The LOR160xW can pose a dangerous electrical hazard if not used properly. Care should be taken to keep the inside of the LOR160xW dry. When the LOR160xW is directly connected to a PC via one of the RS485 adaptors, there is a direct electrical connection between the low voltage logic side of the LOR160xW and the PC. If the LOR160xW is physically damaged causing traces to short or the device is allowed to get wet inside, either through direct contact with water or condensation, the logic side of the LOR160xW can receive direct 120VAC. In that case damage to any connected hardware such as a PC can occur.

**IN NO EVENT SHALL BUYER BE ENTITLED TO INCIDENTAL, CONSEQUENTIAL, OR SPECIAL DAMAGES, NOR SHALL LIGHT-O-RAMA'S LIABILITY EXCEED THE PURCHASE PRICE OF THE GOODS.**

## Appendix A Hexadecimal to Decimal

Hex	Dec	Hex	Dec	Hex	Dec	Hex	Dec
01	01	3D	61	79	121	B5	181
02	02	3E	62	7A	122	B6	182
03	03	3F	63	7B	123	B7	183
04	04	40	64	7C	124	B8	184
05	05	41	65	7D	125	B9	185
06	06	42	66	7E	126	BA	186
07	07	43	67	7F	127	BB	187
08	08	44	68	80	128	BC	188
09	09	45	69	81	129	BD	189
0A	10	46	70	82	130	BE	190
0B	11	47	72	83	131	BF	191
0C	12	48	72	84	132	C0	192
0D	13	49	73	85	133	C1	193
0E	14	4A	74	86	134	C2	194
0F	15	4B	75	87	135	C3	195
10	16	4C	76	88	136	C4	196
11	17	4D	77	89	137	C5	197
12	18	4E	78	8A	138	C6	198
13	19	4F	79	8B	139	C7	199
14	20	50	80	8C	140	C8	200
15	21	51	81	8D	141	C9	201
16	22	52	82	8E	142	CA	202
17	23	53	83	9F	143	CB	203
18	24	54	84	90	144	CC	204
19	25	55	85	91	145	CD	205
1A	26	56	86	92	146	CE	206
1B	27	57	87	93	147	CF	207
1C	28	58	88	94	147	D0	208
1D	29	59	89	95	147	D1	209

## LOR160xW g3

1E	30	5A	90	96	150	D2	210
1F	31	5B	91	97	151	D3	211
20	32	5C	92	98	152	D4	212
21	33	5D	93	99	153	D5	213
22	34	5E	94	9A	154	D6	214
23	35	5F	95	9B	155	D7	215
24	36	60	96	9C	156	D8	216
25	37	61	97	9D	157	D9	217
26	38	62	98	9E	158	DA	218
27	39	63	99	9F	159	DB	219
28	40	64	100	A0	160	DC	220
29	41	65	101	A1	161	DD	221
2A	42	66	102	A2	162	DE	222
2B	43	67	103	A3	163	DF	223
2C	44	68	104	A4	164	E0	224
2D	45	69	105	A5	165	E1	225
2E	46	6A	106	A6	166	E2	226
2F	47	6B	107	A7	167	E3	227
30	48	6C	108	A8	168	E4	228
31	49	6D	109	A9	168	E5	229
32	50	6E	110	AA	170	E6	230
33	51	6F	111	AB	171	E7	231
34	52	70	112	AC	172	E8	232
35	53	71	113	AD	173	E9	233
36	54	72	114	AE	174	EA	234
37	55	73	115	AF	175	EB	235
38	56	74	116	B0	176	EC	236
39	57	75	117	B1	177	ED	237
3A	58	76	118	B2	178	EE	238
3B	59	77	119	B3	179	EF	239
3C	60	78	120	B4	180	F0	240

Specifications	Features
<ul style="list-style-type: none"> <li>• <b>Channel Capacity:</b> 8 amps per channel (25 amp triacs are used.)</li> <li>• <b>Controller Capacity:</b> LOR1600W is 15 amps, LOR1602W is 30 amps</li> <li>• <b>Isolation:</b> Opto isolators are used to isolate high and low voltage sides. Triacs are isolated. Controller is certified UL 508 by ETL.</li> <li>• <b>Supply Voltage:</b> 120VAC 50/60Hz</li> <li>• <b>Power Connections:</b> NEMA 5-15P NEMA 5-15R</li> <li>• <b>Control Input:</b> RS485 via RJ45 or RJ11 jacks</li> <li>• <b>Dimensions:</b> 10<sup>3</sup>/<sub>4</sub>"w x 12"h x 4<sup>3</sup>/<sub>4</sub>"d</li> </ul>	<ul style="list-style-type: none"> <li>• <b>DMX and LOR network support</b></li> <li>• <b>Input:</b> Unit can monitor an input to start a sequence</li> <li>• <b>Unit IDs:</b> Up to 240 controllers. Up to 3,840 channels.</li> <li>• <b>Fading:</b> 1000 levels used for smooth fading effects. Fades from 0.1 to 25 seconds.</li> <li>• <b>Dimming:</b> 100 levels (0%...100%)</li> <li>• <b>Effects:</b> Ramp, Fade, Intensity, Flicker, Shimmer</li> <li>• <b>Sequences:</b> Multiple internal sequences</li> <li>• <b>Presets:</b> High-burn and low-burn settings.</li> </ul>

Light-O-Rama, Inc.  
 Tel: (518) 539-9000  
 Fax: (518) 538-0067  
 info@lightorama.com