

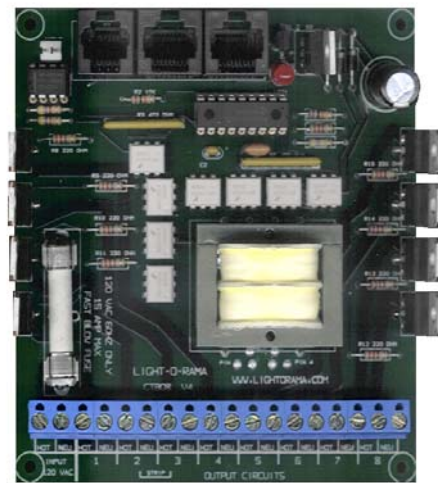

## THE CTB08 LIGHT CONTROLLER

The CTB08 is a one of the components in the Hobbyist line of Light-O-Rama products. The CTB08 must be used in conjunction with the Light-O-Rama software package. This controller generates a number of lighting effects including dimming, ramping and shimmering.

To operate this controller you will also need the Light-O-Rama software package and a Light-O-Rama SC485 RS232/RS485 adaptor to communicate with a PC.



### **FOR USE WITH INCANDESCENT LIGHT ONLY**

**Input: 120VAC 15amp 60Hz**

**Output: 8 Independent Channels 120VAC 2amp 60Hz (without heatsink)**

**CAUTION:** This product requires that the customer have an understanding of electrical wiring. It requires connections to 120VAC. The board has many exposed high voltage connections which are potentially dangerous. The CTB08 should be placed in a safe enclosure ensuring safety to children and pets.

## GETTING STARTED WITH THE CTB08

There are three steps to making the CTB08 useful. It must be wired to accept an AC power source and to distribute AC through its 8 circuits. It must be connected to a computer to receive commands. Using the Light-O-Rama Sequence Editor, a sequence must be created on the PC.

**For the PC to talk to the CTB08, the CTB08 must be assigned an unique Unit ID.** Once AC power has been supplied to the CTB08 the **red LED** will begin to blink. This is an indication that the Unit is functioning and that there is NO COMMUNICATION. Once communications is established, the LED will stop blinking and it will light steadily.

Connect the CTB08 to a PC using the SC485 adaptor and a cable. Using the Light-O-Rama Hardware Utility, assign the CTB08 an unique Unit ID. It is best to assign Unit IDs sequentially starting at 01. Mark this Unit ID on the CTB08 or its enclosure so that you know which Unit it is.

When developing a Sequence to control the lights, the sequence must refer to the CTB08's Unit ID or the lights will not blink. This is true if the sequenced is going to be downloaded as a standalone sequence as well as if the CTB08 is controlled via the PC.

In the Sequence Editor, click on a channel box ( on the left of the screen ). In the menu that pops up, select *Change Channel Options*. You can then Set the Device type to Light-O-Rama Controller and the Unit to the ID that you picked for this Unit. You will also notice that you can specify a Circuit Number. Circuit number 1 corresponds to Output Circuit 1 on the board.

Once you have selected a Unit ID, have the lights connected to the CTB08 and a cable connected to the PC via the SC485, you can control your lights. ( have fun ! )

## POWER IN --- CONNECTING POWER TO THE CTB08

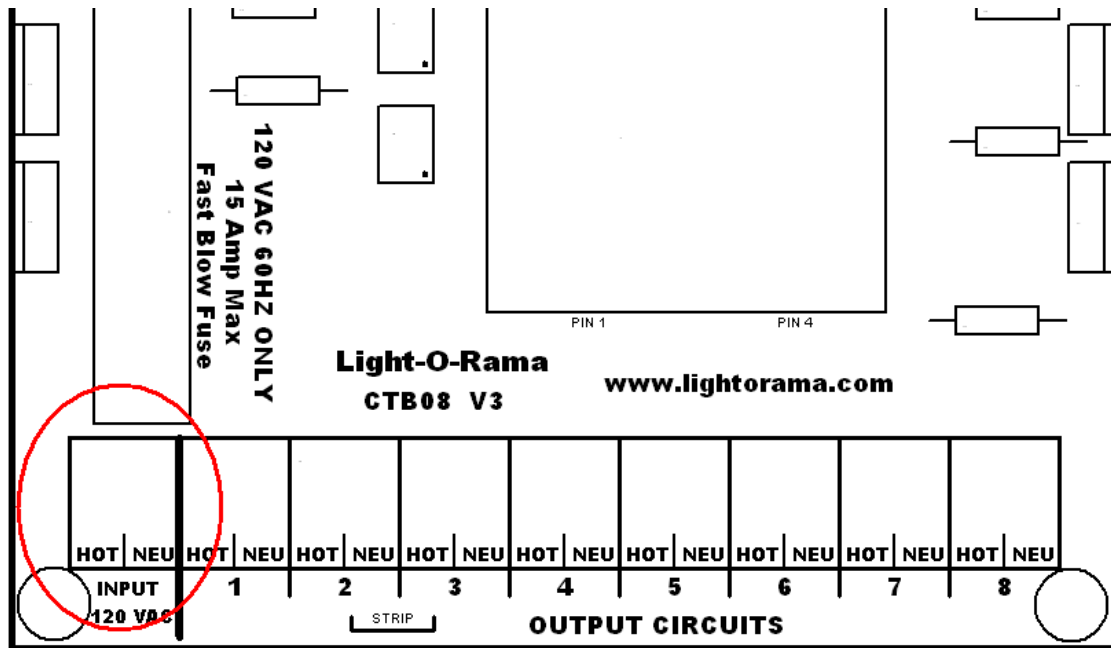

Power coming into the CTB08 is connect on the terminal circled in red. Two wires are connected, a HOT and a NEUtral. Power must be 120 volts AC 60HZ.

Generally HOT wires are BLACK and Neutral wires are WHITE. If you use lamp cord type wire, usually one of the wires has smooth insulation and the other wire has ribbed insulation. The wire with smooth insulation is HOT.

On a standard grounded outlet, the round hole is ground the short slot is HOT and the longer slot is NEUTRAL.

Wires should be carefully stripped to a length (about 1/3 inch) where the bare conductor can be inserted fully into the connector and no bare conductor is exposed.

Frayed wires can cause short circuits that will damage the unit and pose a fire hazard. Carefully inspect all connections before applying power to insure that there are no short circuits.

The screw holding the wire in place must be tightened firmly. Pull on connected wires to ensure good mechanical connection. A loose wire can cause overheating and pose a fire hazard.

**CAUTION: SHOCK HAZARD THIS BOARD HAS MANY EXPOSED HIGH VOLTAGE CONTACTS. DISCONNECT POWER WHEN THE BOARD IS BEING WORKED ON. PLACE BOARD IN SAVE OPERATING ENVIRONMENT**

## POWER OUT – OUTPUT CIRCUITS ON THE CTB08

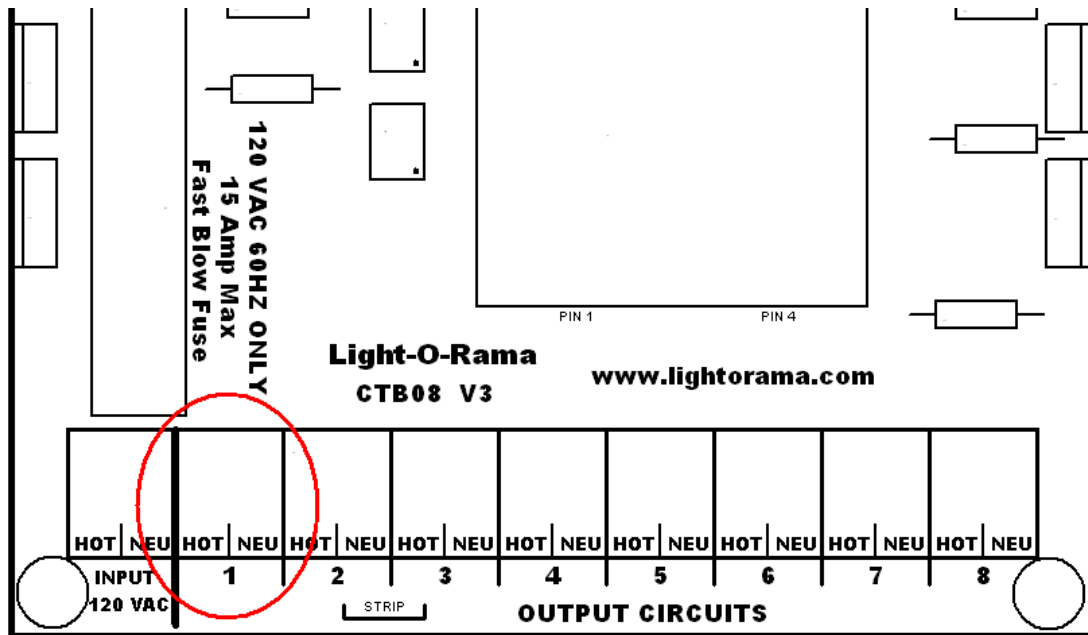

Each output circuit of the CTB08 can handle 2amps without a heat sink. 8 amps with proper heat sinking. There are 8 output channels with HOT/NEU connections. Neutrals can be connected off the card if that is more convenient.

Generally HOT wires are BLACK and Neutral wires are WHITE. If you use lamp cord type wire, usually one of the wires has smooth insulation and the other wire has ribbed insulation. The wire with smooth insulation is the HOT.

On a standard grounded outlet, the round hole is ground the short slot is HOT and the longer slot is neutral.

Wires should be carefully stripped to a length (about 1/3 inch) where the bare conductor be inserted fully into the connector and no bare conductor is exposed.

Frayed wires can cause short circuits that will damage the unit and pose a fire hazard. Carefully inspect all connections before applying power to insure that there are no short circuits.

The screw holding the wire in place must be tightened firmly. Pull on connected wires to insure good mechanical connection. A loose wire can cause overheating and pose a fire hazard.

**CAUTION: SHOCK HAZARD THIS BOARD HAS MANY EXPOSED HIGH VOLTAGE CONTACTS. DISCONNECT POWER WHEN THE BOARD IS BEING WORKED ON. PLACE BOARD IN SAFE OPERATING ENVIRONMENT**

# ELECTRICAL CONNECTION OPTIONS

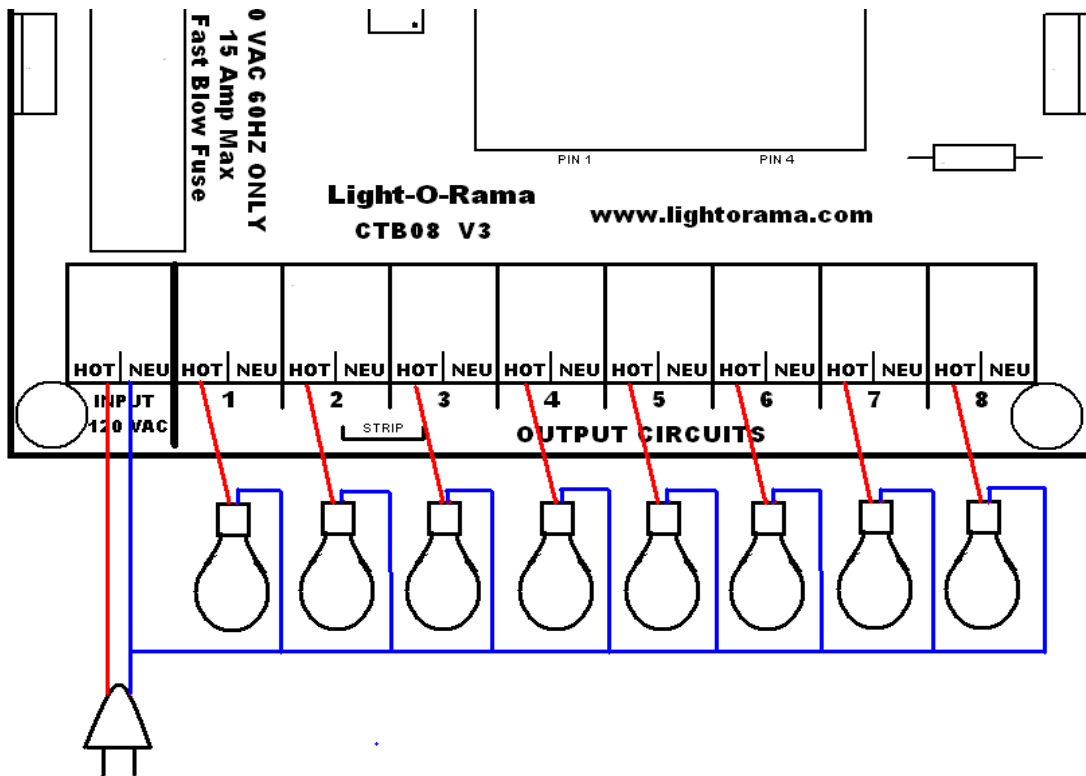
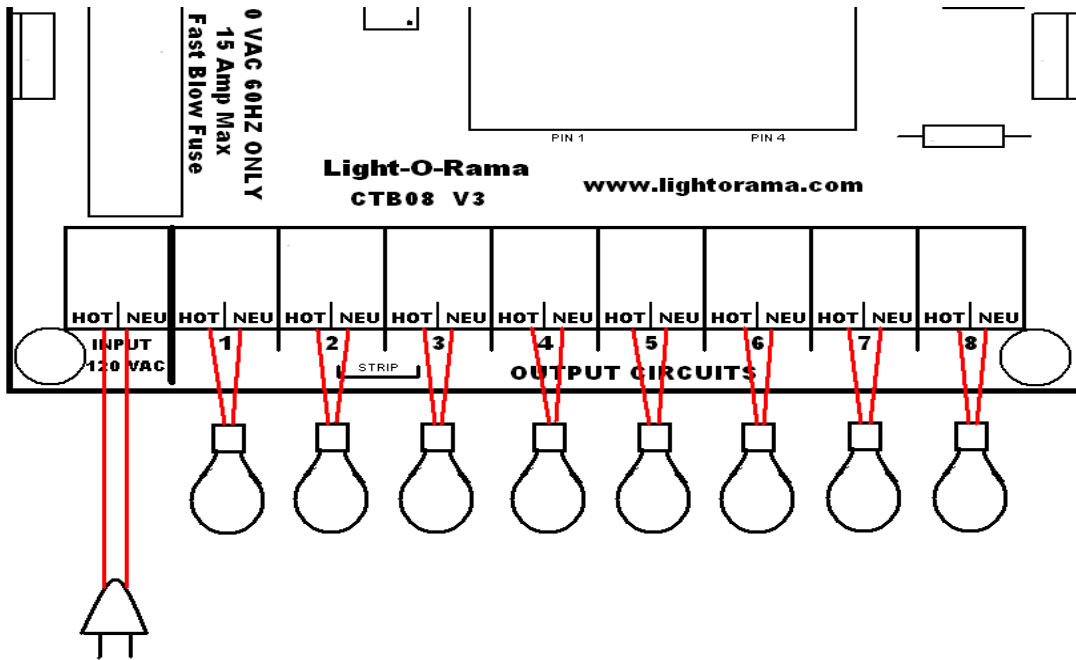

# CONNECTING THE CTB08 TO THE PC

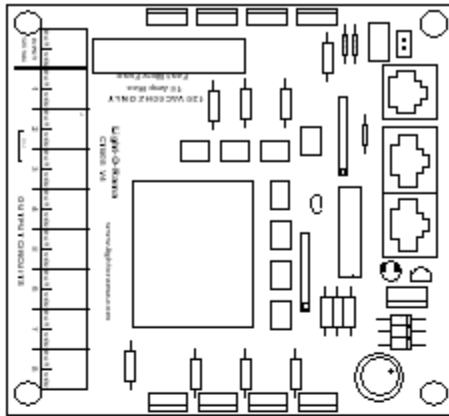

**in**  
**From PC or Director Unit**

**out**

The Units are connected in a daisy chain manor. You cannot splice or put Ys in the cable. The cables must connect from one unit to the next as show here.

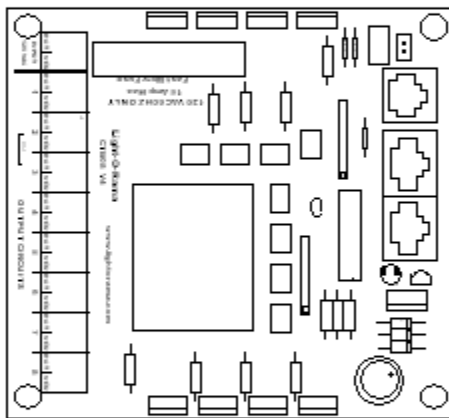

**in**

**out**

If TELEPHONE wire is used the telephone in connector must be used for the INPUT. Output can be any type of cable and can use either of the large connectors.

If DATA cable is used then the two large connectors must be used. With Data cable there is not IN or OUT specific connectors.

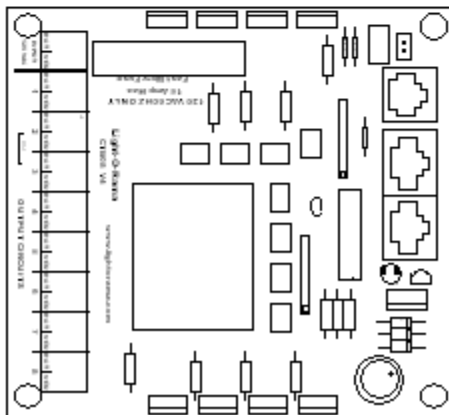

**in**

**out**

**Phone Cable**

**Data Cable**

**To next unit**

**NOTE: The small phone wire connector is only used for INPUT never for OUTPUT to the next unit.**

## THE INPUT CONNECTOR ON THE CTB08 (used for standalone operation)

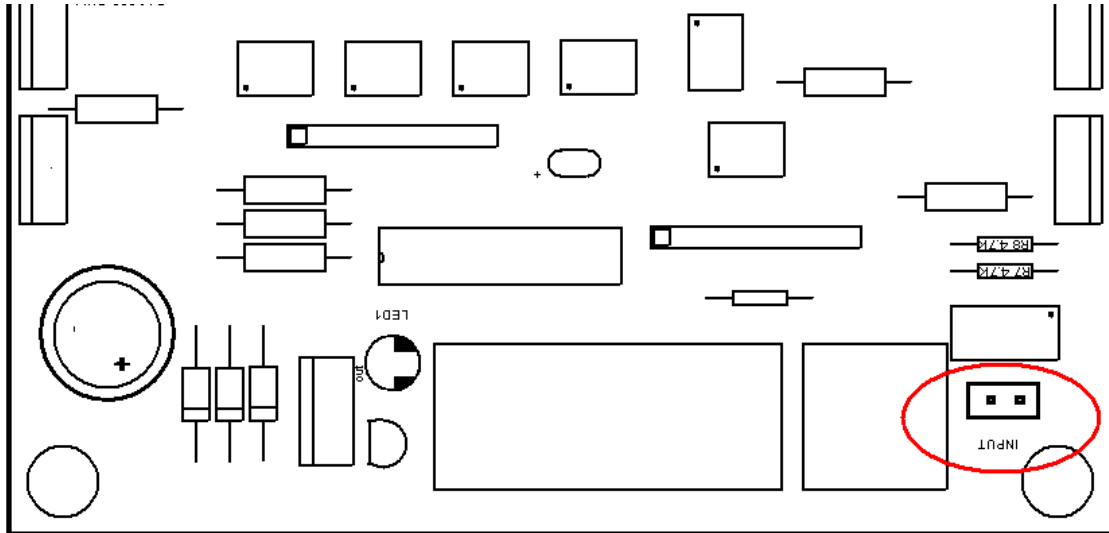

The input connector noted above is used during standalone operation of the unit. When used in standalone mode, the CTB08 can operate without a connection to the PC. To operate in this mode, an animation sequence must be installed on the CTB08 using the Light-O-Rama Hardware Utility. See the HELP files with the Hardware Utility for sequence download instructions.

Once a standalone sequence has been loaded by the Light-O-Rama Hardware Utility, the Input connector is used to start and stop the sequence. Generally the supplied jumper will remain in place on the connector. With the jumper in place, the standalone sequence will operate anytime the unit is powered.

A normally open switch can be attached to the jumper to provide low voltage control of the unit. Once activated (closed connection) the unit will operate for one pass of the downloaded sequence.

**WARNING: The CTB08 can pose a dangerous electrical hazard if not used properly. Care should be taken to keep the CTB08 dry. When the CTB08 is directly connected to a PC via a SC485 adaptor, there is a direct electrical connection between the logic side of the CTB08 and the PC. If the CTB08 is physically damaged causing traces to short or the Unit is allowed to get wet either through direct contact with water or condensation the logic side of the CTB08 can receive direct 120VAC. In that case damage to any connected hardware such as a PC can occur.**

**IN NO EVENT SHALL BUYER BE ENTITLED TO INCIDENTAL, CONSEQUENTIAL, OR SPECIAL DAMAGES, NOR SHALL LIGHT-O-RAMA'S LIABILITY EXCEED THE PURCHASE PRICE OF THE GOODS.**